

Description

Intelligent and complex systems as well as the electrification of loads currently play a decisive role in the development of on-board electrical systems.

The SCS200 is the right answer to these requirements. It is an intelligent power distribution system, enabling decentralised control and monitoring of loads via CAN bus. The design features a PCB-based power distribution in a compact IP66/67 enclosure.

The SCS200 modules are plug & play solutions which help reduce wiring time and space requirements. Its comprehensive diagnosis capability (integral load protection, load current and voltage measuring, output status) and its integral CAN connection enable predictive maintenance and implemented load management.



Applications

Typical applications:

- Agricultural machinery, construction machinery, special vehicles, trucks and buses
- Decentralised power distribution downstream the ECU
- Vehicle modernisation and easy system extension through standardised CAN components

Benefits

- Predictive maintenance and load management through comprehensive diagnostic functions (current, voltage, status)
- Facilitated wiring through plug & play solution with CAN connection
- Space-saving, flexible installation through compact IP66/67 housing
- Increased safety through integral electronic load protection

Approvals

Approval authority	Logo	Directive	Approvals
KBA	E1 10R-059019	ECE-R10	

Compliance



Example versions

Ordering number keys	Short description
SCS200-SC08-00-01-C1-01	8 fully electronic load outputs, DC 12 V
SCS200-SC12-00-01-C1-01	12 fully electronic load outputs, DC 12 V, J1939
SCS200-SC12-00-02-C4-01	12 fully electronic load outputs, DC 24 V, CANopen
SCS200-SC12-00-04-C4-01	12 fully electrical load outputs, DC 48 V, CANopen
SCS200-RC08-00-03-C1-01	8 load outputs relays & fuses, DC 12/24 V (not equipped), J1939

Technical data SCS200-SC... (T_U = 25 °C at U_N = 12 V)

Rated voltage	DC 12 V
Operating voltage range	9 V ... 16 V
Rated current per channel	8 channel version: 4 x 30 A, 4 x 10 A 12 channel version: 4 x 30 A, 8 x 10 A Both versions allow the 10 A channels to be connected in parallel.
Total current	8 channel version: 120 A 12 channel version: 150 A
Analogue inputs	6 analogue inputs (0 – 10 V) ³⁾
Temperature range ¹⁾	-40 ... +85 °C
Quiescent current	< 0.5 mA
Electronic load protection	Trip current 1: 1.3 x I _N Trip delay 1: 200 ms Trip current 2: 3 x I _N (channels 1-4: max. 60 A, channels 5-12: max. 22.5 A) Trip delay 2: 30 ms (can be deactivated via software)
Bus communication	CAN 2.0B / SAE J1939 / CANopen 50 kBit/s / 100 kBit/s / 125 kBit/s / 250 kBit/s / 500 kBit/s / 1 MBit/s
Degree of protection	IP66, IP67 according to ISO 20653
Environmental tests	according to ISO 16750
EMC	according to ECE-R10 (E1)
Reverse polarity protection	Supply (reverse polarity protected) and load outputs (reverse polarity conductive)
Voltage drop ²⁾	Channel 1-4 (at 24 A): max. 50 mV Channel 5-12 (at 8 A): max. 75 mV
Vibration resistance	RMS - acceleration: 57.9 m/s ²
Shock resistance	50 g/6 ms half sine
Housing material	PA66-GF25FR V-0
Mass	410 g
Dimensions	159 x 159 x 44 mm

¹⁾ Current carrying capacity see derating (SCS200 operating manual)

²⁾ Cannot be ensured over the entire life span.

³⁾ Inputs 1 to 3 can be used for physical module addressing (PMA).

Technical data SCS200-SC... (T_U = 25 °C at U_N = 24 V)

Rated voltage	DC 24 V
Operating voltage range	9 V ... 32 V
Rated current per channel	2 x 25 A, 10 x 10 A Parallel connection of the 10 A channels is possible (3 x 25 A, 9 x 10 A possible at 100 A total current)
Total current	120 A
Analogue inputs	5 analogue inputs (0 – 10 V) ³⁾
Temperature range ¹⁾	-40 ... +85 °C
Quiescent current	< 1 mA
Electronic load protection ⁴⁾	Trip current 1: 1.3 x I _N Trip delay 1: 200ms Trip current 2: 3 x I _N (channels 1-3: max. 75 A, channels 4-12: max. 30 A) Trip delay 2: 30 ms (can be deactivated via software)
Bus communication	CAN 2.0B / SAE J1939 / CANopen 50 kBit/s / 100 kBit/s / 125 kBit/s / 250 kBit/s / 500 kBit/s / 1 MBit/s
Degree of protection	IP66, IP67 according to ISO 20653
Environmental tests	according to ISO 16750
EMC	according to ECE-R10 (E1)
Reverse polarity protection	Control voltage: reverse polarity protected Load voltage: reverse polarity conductive (60 S according to ISO16750-2)
Voltage drop ²⁾	Channel 1-3 (at 20 A): max. 60 mV Channel 4-12 (at 8 A): max. 60 mV
Vibration resistance	RMS - acceleration: 57.9 m/s ²
Shock resistance	50 g/6 ms half sine
Housing material	PA66-GF25FR V-0
Mass	410 g
Dimensions	159 x 159 x 44 mm

Technical data SCS200-SC... (T_U = 25 °C at U_N = 48 V)

Rated voltage	DC 48 V (load) DC 12/24 V (control)
Operating voltage range	9 V ... 60 V (load) ⁵⁾ 9 V... 32 V (control)
Rated current per channel	3 x 15 A, 9 x 10 A Parallel connection of the 10 A channels is possible
Total current	90 A
Analogue inputs	5 analogue inputs (0 – 10 V) ³⁾
Temperature range ¹⁾	-40 ... +85 °C
Quiescent current	< 1 mA
Electronic load protection ⁴⁾	Trip current 1: 1.3 x I _N Trip delay 1: 200ms Trip current 2: 3 x I _N (channels 1-3: max. 45 A, channels 4-12: max. 30 A) Trip delay 2: 30ms (can be deactivated via software)
Bus communication	CAN 2.0B / SAE J1939 / CANopen 50 kBit/s / 100 kBit/s / 125 kBit/s / 250 kBit/s / 500 kBit/s / 1 MBit/s
Degree of protection	IP66, IP67 according to ISO 20653
Environmental tests	according to ISO 16750
EMC	according to ECE-R10 (E1)
Reverse polarity protection	Control voltage: reverse polarity protected Load voltage: reverse polarity conductive
Voltage drop ²⁾	Channel 1-3 (at 12 A): max. 60 mV Channel 4-12 (at 8 A): max. 75 mV
Vibration resistance	RMS - acceleration: 57.9 m/s ²
Shock resistance	50 g/6 ms half sine
Housing material	PA66-GF25FR V-0
Mass	410 g
Dimensions	159 x 159 x 44 mm

¹⁾ Current carrying capacity see derating (SCS200 operating manual)

²⁾ Cannot be ensured over the entire life span.

³⁾ Inputs 1- 3 can be used for physical module addressing (PMA).

⁴⁾ Differentiation of CAN diagnostic information between trip current 1 & 2

¹⁾ Current carrying capacity see derating (SCS200 operating manual)

²⁾ Cannot be ensured over the entire life span.

³⁾ Inputs 1- 3 can be used for physical module addressing (PMA).

⁴⁾ Differentiation of CAN diagnostic information between trip current 1 & 2

⁵⁾ According to ISO21780 the rated voltage ranges up to 52 V; the transient voltage limit is defined for 54 V and exceeding 54 V is the overvoltage range, which causes the SCS200 to switch off the load outputs as a self-protection measure when detected.

Technical data SCS200-RC... (T_U = 25 °C at U_N = 12 V/ 24 V)

Rated voltage	DC 12 V/24 V
Operating voltage range	9 V ... 32 V
Rated current per channel	4 x 30 A, 4 x 10 A
Total current	120 A
Analogue inputs	6 analogue inputs (0 – 10 V) ³⁾
Temperature range ¹⁾	-40 ... +85 °C
Quiescent current	12 V: < 1.2 mA 24 V: < 2.4 mA
Electronic load protection	Trip current 1: 1.3 x I _N Trip delay 1: 200ms Trip current 2: 3 x I _N (channels 1-4: max. 60 A, channels 5-8: max. 22.5 A) Trip delay 2: 30 ms (can be deactivated via software)
Failsafe	ATO blade fuses as back-up elements (not included in the delivery scope)
Bus communication	CAN 2.0B / SAE J1939 / CANopen 50 kBit/s / 100 kBit/s / 125 kBit/s / 250 kBit/s / 500 kBit/s / 1 MBit/s
Degree of protection	IP66, IP67 according to ISO 20653
Environmental tests	according to ISO 16750
EMC	according to ECE-R10 (E1)
Reverse polarity protection	Supply (reverse polarity protected)
Short circuit resistance	Depending on the equipped relay. Example: TE V23074-A2002-A403 (30 A channel): > 100 A at 24 V E-T-A ESR10-NC2A4HB-00-D2-10A (10 A channel): > 60 A at 24 V
Voltage drop ²⁾	Channel 1-4 (at 24 A): max. 50 mV Channel 5-12 (at 8 A): max. 75 mV
Vibration resistance	RMS - acceleration: 57.9 m/s ²
Shock resistance	50 g/6 ms half sine
Housing material	PA66-GF25FR V-0
Mass	630 g (fully equipped)
Dimensions	159 x 159 x 62 mm

¹⁾ Current carrying capacity see derating (SCS200 operating manual)

²⁾ Cannot be ensured over the entire life span.

³⁾ Inputs 1 to 3 can be used for physical module addressing (PMA).

Ordering number code

Type	SCS200 Intelligent power distribution system - Smart Control Systems
Load outputs	SC Semi-conductors RC Relay socket and ATO fuse socket
Number of channels	08 8 load outputs (only for RC- and 12V SC-versions) 12 12 load outputs (only for SC version possible)
Equipment	00 Standard (for RC versions without relays and fuses)
Rated voltage	01 12 V DC (only for SC versions) 02 24 V DC (only for SC versions) 03 12 / 24 V DC (only for RC versions) 04 48 V DC (only for SC versions)
CAN standard	C1 SAE J1939 compatible (only for RC- and 12 V SC-versions) C2 SAE J1939 compatible, without internal CAN termination C3 CANopen compatible (only for RC- and 12 V SC-versions) C4 CANopen compatible, without internal CAN termination
Software configuration	01 Standard configuration, locally configurable via CAN
Ordering example	SCS200- SC 08 - 00 - 01 - C1 - 01

SCS200- SC 08 - 00 - 01 - C1 - 01 Ordering example

All information and data given on our products are accurate and reliable to the best of our knowledge, but E-T-A does not accept any responsibility for the use in applications which are not in accordance with the present specification. E-T-A reserves the right to change specifications at any time in the interest of technical improvement. Dimensions are subject to change without notice. Please enquire for the latest dimensional drawing with tolerances if required. All dimensions, data, pictures and descriptions are for information only and are not binding. Amendments, errors and omissions excepted. Ordering codes of the products may differ from their marking.

CAN communication CAN 2.0B / SAE J1939 / CANopen

Receiving (Rx)

- ON/OFF operation of load outputs
- Query of measured values per load output
 - current and voltage
- Query of analogue inputs
- Query of total current and U_{Bat}
- Query of load output status
 - Switching status and error diagnosis (ON, OFF, overload, open load)
- Activate sleep mode
- Initiate module
 - ON and OFF delay per channel (0.5 s ... 2.7 h)
 - Module ID
 - Rated current per channel
 - 10 A channels: 1 A ... 10 A
 - 30 A channels: 5 A ... 30 A
 - Parallel connection of load outputs
 - PMA status
 - Safe states

Transmitting (Tx)

- Actual total current U_{Bat} (accuracy: ± 3 A or ± 3 % at U_N)
- Actual total current per channel (accuracy: ± 0.5 A)
- Actual voltage per channel (accuracy: ± 3 % at U_N)
- Voltage values of the analogue inputs (0-10 V, accuracy: ± 200 mV)
- Error diagnosis per channel (normal, Trip 1 (overload), Trip 2 (short circuit), Open load)
- Switching status of the load outputs
- Information for module configuration
- Heart Beat according to CANopen
- Cyclic diagnosis information or sent upon request

The SCS200 supports Address Claiming according to SAE J1939-81.
The SCS200 supports LSS according to CiA 305.

For module initialisation/configuration no special configuration software is required.

For a list of all related CAN frames (DBC, SYM and EDS files available) and for further information, please refer to the separate operating manual:



SCS®200
<https://www.e-t-a.de/qr1042/>

Dimensions SCS200-SC...

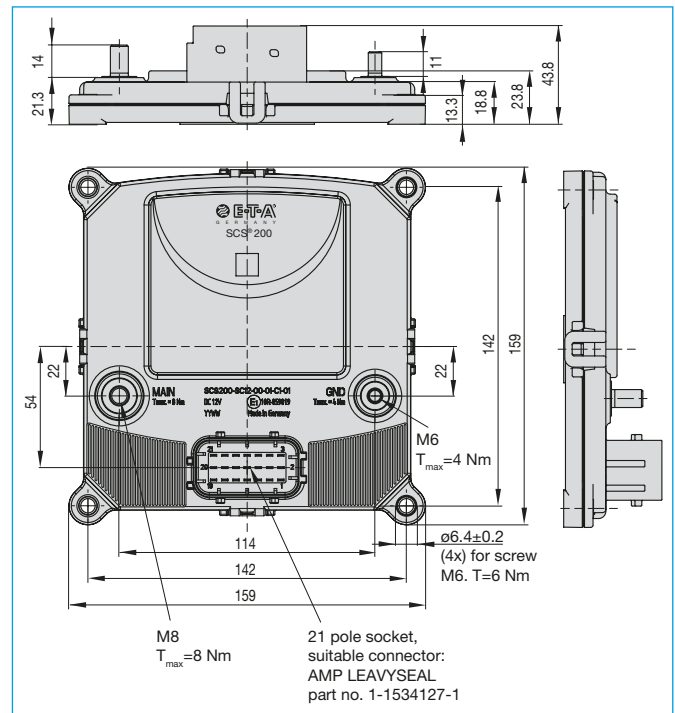

Pin assignment SCS200-SC08-...

Main terminals

U_{Bat}: M8 screw terminal (marking: MAIN)
GND: M6 screw terminal (marking: GND)

21-pole plug-in connector
Mating connectors: Tyco AMP
LEAVYSEAL 1-1534127-1

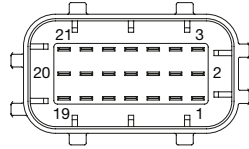

Pin	Name	Description
1	n.c.	not connected
2	LOAD_8	10 A load
3	LOAD_4	30 A load
4	n.c.	not connected
5	IN_A_1	Analogue input 1 / PMA 1
6	LOAD_7	10 A load
7	n.c.	not connected
8	IN_A_3	Analogue input 3 / PMA 3
9	LOAD_3	30 A load
10	n.c.	not connected
11	IN_A_4	Analogue input 4
12	LOAD_6	10 A load
13	IN_A_2	Analogue input 2 / PMA 2
14	IN_A_5	Analogue input 5
15	LOAD_2	30 A load
16	IN_A_6	Analogue input 6
17	WAKE_SIGNAL_IN	Wake up input
18	LOAD_5	10 A load
19	CAN_H_OUT	CAN high
20	CAN_L_OUT	CAN low
21	LOAD_1	30 A load

Pin assignment SCS200- SC12-...

Main terminals

U_{Bat}: M8 screw terminal (marking: MAIN)
GND: M6 screw terminal (marking: GND)

21-pole plug-in connector
Mating connectors: Tyco AMP
LEAVYSEAL 1-1534127-1

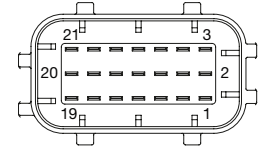

Pin	Name		Description	
	12V	24 V / 48 V	12V	24 V / 48 V
1	LOAD_9		10 A load	
2	LOAD_8		10 A load	
3	LOAD_4	LOAD_3	30 A load	10 A / 15 A load ²⁾
4	LOAD_10		10 A load	
5	IN_A_1		Analogue input 1 / PMA 1	
6	LOAD_7		10 A load	
7	LOAD_11		10 A load	
8	IN_A_3		Analogue input 3 / PMA 3	
9	LOAD_3	LOAD_6	30 A load	10 A load
10	LOAD_12		10 A load	
11	IN_A_4		Analogue input 4	
12	LOAD_6	LOAD_4	10 A load	
13	IN_A_2		Analogue input 2 / PMA 2	
14	IN_A_5		Analogue input 5	
15	LOAD_2		30 A load	25 A / 15 A load ²⁾
16	IN_A_6	U_Control	Analogue input 6	Logic Supply ¹⁾
17	WAKE_SIGNAL_IN		Wake up input	
18	LOAD_5		10 A load	
19	CAN_H_OUT		CAN high	
20	CAN_L_OUT		CAN low	
21	LOAD_1		30 A load	25 A / 15 A load ²⁾

¹⁾ For the 24 V & 48 V versions, the pin 16 is designed as supply voltage terminal for the control.

²⁾ For the 24 V version, the load outputs 1 & 2 are designed for a maximum current of 25 A. The load outputs 1, 2 and 3 of the 48 V version are designed for a maximum current of 15 A. Reducing the total current to 100 A for the 24 V variant allows load output 3 to be used with 25 A (24 V).

Dimensions SCS200-RC...

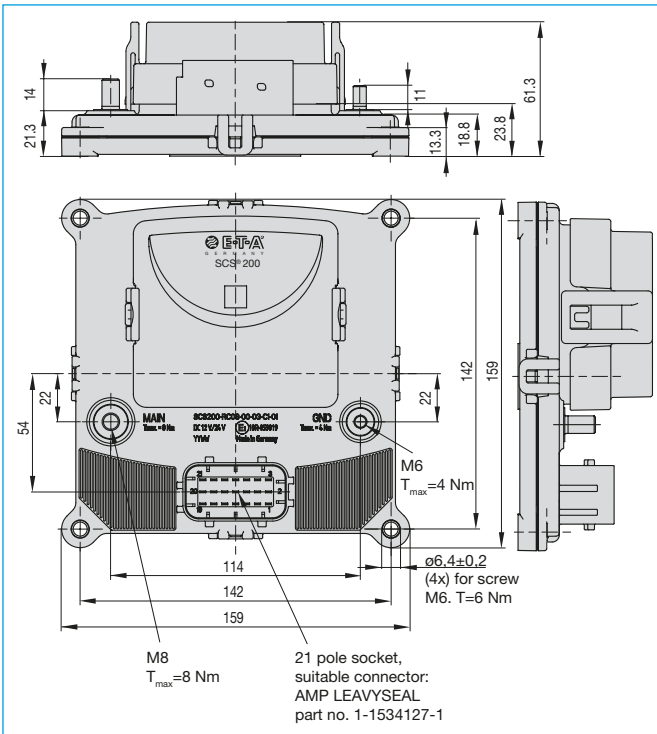

Pin assignment SCS200-RC08-...

Main terminals

U_{Bat} : M8 screw terminal (marking: MAIN)
GND: M6 screw terminal (marking: GND)

21-pole plug-in connector

Mating connectors: Tyco AMP
LEAVYSEAL 1-1534127-1

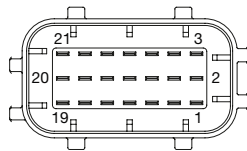

Pin	Name	Description
1	n.c.	not connected
2	LOAD_8	10 A load
3	LOAD_4	30 A load
4	n.c.	not connected
5	IN_A_1	Analogue input 1 / PMA 1
6	LOAD_7	10 A load
7	n.c.	not connected
8	IN_A_3	Analogue input 3 / PMA 3
9	LOAD_3	30 A load
10	n.c.	not connected
11	IN_A_4	Analogue input 4
12	LOAD_6	10 A load
13	IN_A_2	Analogue input 2 / PMA 2
14	IN_A_5	Analogue input 5
15	LOAD_2	30 A load
16	IN_A_6	Analogue input 6
17	WAKE_SIGNAL_IN	Wake up input
18	LOAD_5	10 A load
19	CAN_H_OUT	CAN high
20	CAN_L_OUT	CAN low
21	LOAD_1	30 A load

Relay assignment SCS200-RC08-...

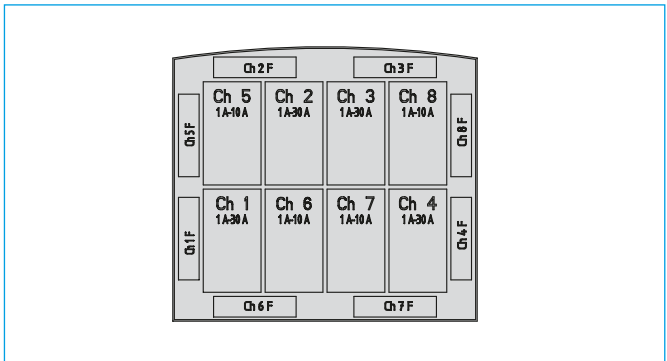

Cable cross sections & mounting

Main terminal cross section:

$\geq 50 \text{ mm}^2$ (for positive supply voltage, GND stud for logic supply only)

The cross section must be adjusted to the actual current and the operating temperature conditions. The device's temperature behaviour improves with larger terminal cross sections.

Load terminal cross section:

30 A channels: AWG12 or 4 mm^2

10 A channels: AWG12 or $\geq 2.5 \text{ mm}^2$

The cross section must be adjusted to the actual current and the operating temperature conditions. The device's temperature behaviour improves with larger terminal cross sections.

Mounting screws:

M6, max. 6 Nm tightening torque

(not included in the scope of delivery)

Accessories: Equipment for SCS200-RC08-...

Note: The SCS200-RC08-00-03-xx-01 version is delivered unequipped. You can order additional accessories, which will be enclosed with the delivery.

Relays and fuses for 12 V DC: X22392701

Contents:

- 4 x 10 A Micro relay E-T-A ESR10-NC3A4HB-00-D1-10A
- 4 x 30 A Micro relay E-T-A ESR10-NC3A4HB-00-D1-30A
- 4 x 15 A Blade fuse MTA 380029 blue
- 4 x 40 A Blade fuse MTA 380035 orange

Relays and fuses for 24 V DC: X22392702

Contents:

- 4 x 10 A Micro relay E-T-A ESR10-NC3A4HB-00-D2-10A
- 4 x 30 A Micro relay Tyco V23074-A2002-A403
- 4 x 15 A Blade fuse MTA 380029 blue
- 4 x 40 A Blade fuse MTA 380035 orange

Accessories: USB/CAN converters

USB/CAN converter: XPP-USBC0
XPP-USBC1 (opto-decoupled)

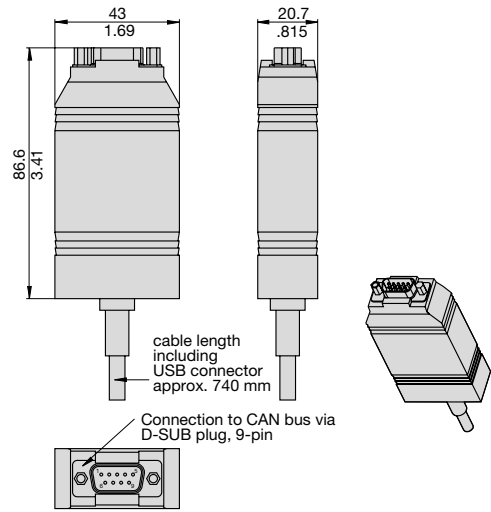

Pin assignment D-SUB output plug

PIN	assignment
2	CAN-L
7	CAN-H

This is a metric design and millimeter dimensions take precedence. Applicable for nominal dimensions without direct tolerance indication: DIN ISO 286 ± IT 13. Refer to product datasheet for installation and safety instructions.

All information and data given on our products are accurate and reliable to the best of our knowledge, but E-T-A does not accept any responsibility for the use in applications which are not in accordance with the present specification. E-T-A reserves the right to change specifications at any time in the interest of technical improvement. Dimensions are subject to change without notice. Please enquire for the latest dimensional drawing with tolerances if required. All dimensions, data, pictures and descriptions are for information only and are not binding. Amendments, errors and omissions excepted. Ordering codes of the products may differ from their marking.