

Description

The E-T-A Current Protector is designed to monitor the primary current of low-voltage transformers for halogen fittings. After system installation, the admissible current range can be stored by operating the storage button. If the admissible range is exceeded (e. g. by overloads or short-circuit), the Protector will immediately disconnect the system. Underload (e. g. through defective terminal connections) will also cause system disconnection. Fault conditions are indicated by the integral LED. The system can be reconnected by turning the light switch on again once the cause of failure has been remedied.

Typical applications

- Low-voltage halogen lighting systems
- Can generally be used with sensor touch dimmers (please enquire)
- In sub-distribution
- Low-voltage transformers (no electronic transformers)

Features

- Eliminating fire hazard
- Storage of actual lamp load by push button
- LED fault indication
- Suitable for lighting systems with dimmers
- Passive relay for long use
- Mounting on symmetric rail
- Unaffected by inrush currents

Ordering information

Type No.	
E-1078-4	Current Protector for low voltage lighting systems
Version	
2	with storage button, capacity up to 400 W
3	with storage button, capacity up to 600 W
Housing	
1	track-mountable housing
Voltage rating	
AC 230 V	voltage rating AC 230 V
Rated load	
60-300 W	lamp capacity 60...300 W
100-400 W	lamp capacity 100...400 W
300-600 W	lamp capacity 300...600 W
E-1078-4 2 1 - AC 230 V - 100-400 W	ordering example



E-1078-421-...

Technical data

Protective function	short-circuit, overload, underload
Lamp load	60...300 W 100...400 W 300...600 W
Monitoring window	typically: ± 40 W
Response times typ.:	overload 200 ms...2 s (depending on overload) short-circuit 200 ms underload 3 s
Voltage rating	AC 230 V ± 10 %, 50 Hz
Interrupting capacity	relay contact 8 A
Dimmer operation	between 35 and 100 % of the rated load stored
Temperature range	0...+45 °C
Degree of protection:	IP20 housing DIN 40050 IP20 terminals DIN 40050
Housing	track-mountable housing (for DIN rails)
Connection	screw terminals
VDE approval	Reg. Nr. 8319 to VDE 0160

Dimensions

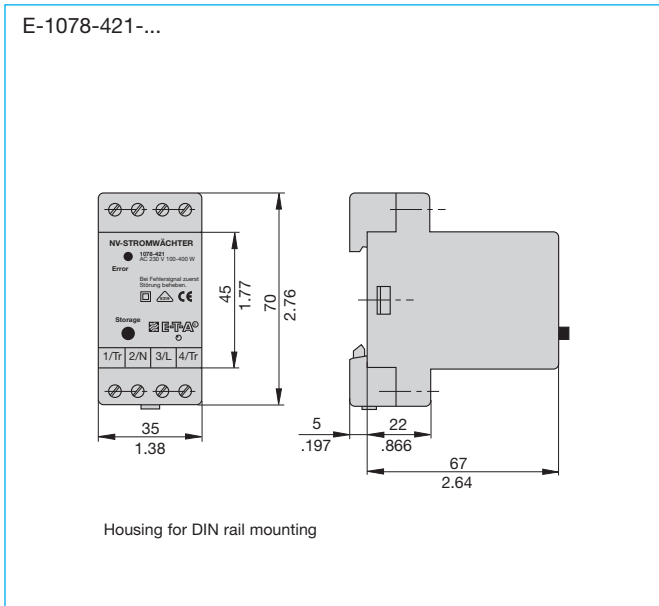

This is a metric design and millimeter dimensions take precedence ($\frac{\text{mm}}{\text{inch}}$)

Basic circuit diagram

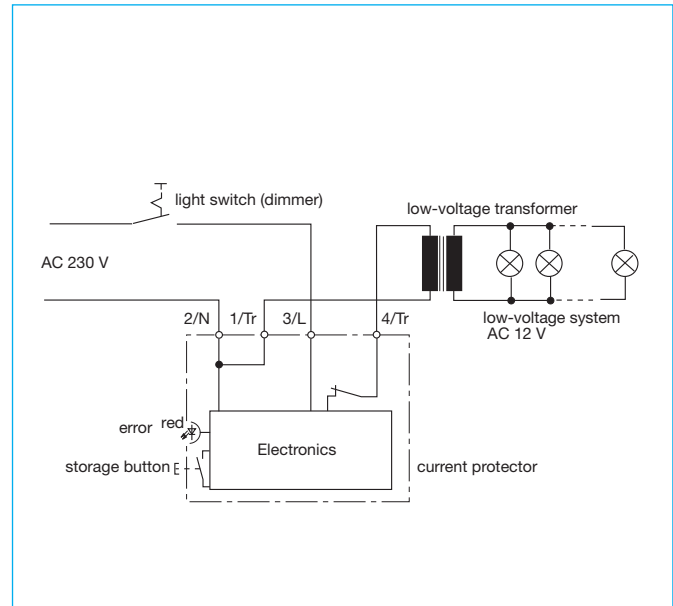

Instructions for installation and adjustment

For correct performance, the E-T-A Current Protector shall be used on the primary side before the low-voltage transformer. It should be connected behind the light switch and the dimmer, if any, into the line to the transformer.

Caution: Installation by skilled personnel only!

- Install the low-voltage system with the desired rated capacity.
- Set dimmer, if any, at the maximum value (turn button to right-side stop).
- Switch the light on.
- Keep storage button on the Protector pressed for approx. 5 sec to store the lamp load installed.
- The stored value will be maintained even when the lighting is switched off.
- A new rated load can be set by pressing the storage button again.

Caution:

- Observe max. transformer capacity!
- Eliminate unsymmetrical load on the power feed caused by half-wave operation.
- Use separate power cables when several low-voltage systems are operated in parallel.

Protective functions

Immediate disconnection upon short-circuit and overloads when additional lamps (loads) are connected.
Underload disconnection when lamps (loads) are removed or upon defective terminal connections.

Action in the event of faults:

Switch the lighting system off by means of the light switch. Remedy cause of failure (call in skilled personnel, if necessary!).

Possible faults:

- defective lamps
- loose or broken terminals or screw connections
- short-circuit
- additional lamps

Reset function

- provided when the lighting is reconnected by switching the light switch on. The lamp load is not re-stored.
- If the load conditions have changed after remedying the fault, the Protector will switch off within max. 3 sec after reconnection. To re-store the lamp load, keep the button pressed for approx. 5 sec.

All dimensions without tolerances are for reference only. In the interest of improved design, performance and cost effectiveness the right to make changes in these specifications without notice is reserved. Product markings may not be exactly as the ordering codes. Errors and omissions excepted.