

## Description

The E-T-A Zero Current Monitor comprises a monitoring circuit with a current transformer and an opto decoupled output circuit with a triac (with AC output circuit) or transistor (with DC output circuit). The current transformer in the monitoring circuit does not only supply the input signal but also the very low power consumption of the Monitor. Zero current monitors are generally used to monitor circuits for wire breakage. The E-T-A Zero Current Monitor E-1076-SR may also be used to switch on an elapsed-hour meter. In this case the opto decoupled triac or transistor output will provide the control signal for the meter as soon as the load to be monitored is switched on. The E-T-A Zero Current Monitor is supplied in a compact moulded housing with screw terminals for mounting on DIN EN 50022 and DIN EN 50035 rails.

## Typical applications

- Wire break monitoring
- Control of elapsed-hour meters
- Life testing (e. g. lamps)
- Monitoring of heater elements (e. g. in furnaces)

## Features

- No auxiliary voltage required
- Compact design
- Expandable by external current transformers
- operation of **monitoring circuit > AC 250 V** only via additional external current transformer

## Ordering information

Type No.	Zero Current Monitor	
E-1076-SR	AC 20 A	<b>Monitoring range</b>
		load current 0.2 to 20 A
		<b>Output circuit</b>
		AC 250 V AC 12...250 V
		DC 60 V DC 2...60 V
E-1076-SR	- AC 20 A	AC 250 V ordering example



**E-1076-SR**

## Technical data

### Monitoring circuit

Max. current rating	AC 20 A
Load current $I_{min}$ . red LED <u>lights</u> when $I_{load}$ is	$\geq 500$ mA (E-1076-SR-AC 20 A-AC 250 V) $\geq 200$ mA (E-1076-SR-AC 20 A-DC 60 V)
Zero current (wire break) red LED does <u>not light</u> when $I_{load}$ is	$< 50$ mA
Load current $I_{max}$ . at +25 °C ambient temp. (derating)	20 A
Voltage rating $U_N$	0 - 250 V AC

### Output circuit (conductive at $I_{load} > I_{min}$ )

Voltage rating $U_N$	AC 12...250 V	DC 2...60 V
Output current $I_{Amax}$	200 mA	50 mA

### General data

Insulation resistance	10 M $\Omega$ at 500 V DC
Dielectric strength	control circuit to output circuit: 1 kV
Mounting	rail DIN EN 50022-35x7.5, or rail DIN EN 50035-G32
Temperature range	0...+60 °C
Degree of protection:	IP20 housing DIN 40050 IP20 terminals DIN 40050
Terminals	screw terminals
Cable size	1 x 2.5 mm <sup>2</sup> each (AWG 14)
Housing dimensions	17 x 63 x 64 mm (width x height x depth)

## Dimensions

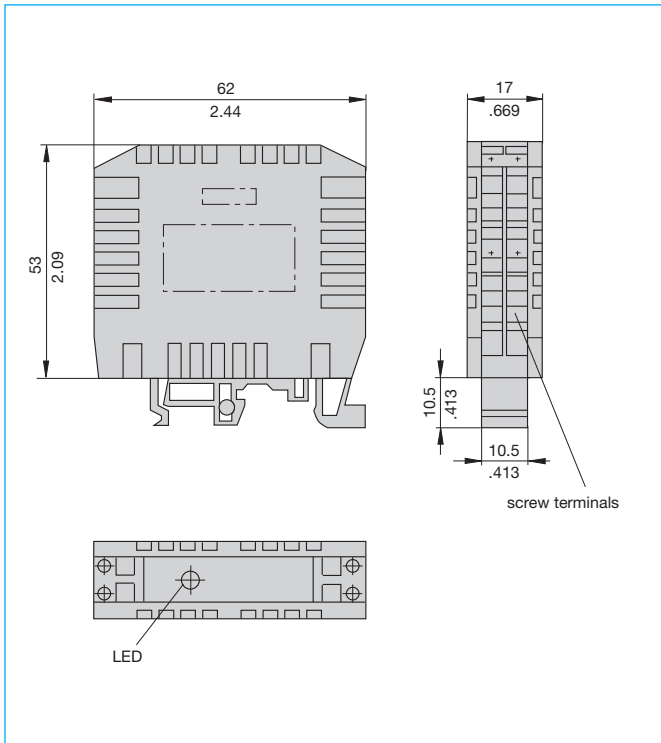

This is a metric design and millimeter dimensions take precedence ( $\frac{\text{mm}}{\text{inch}}$ )

## Connection diagrams

### Output circuit AC 250 V

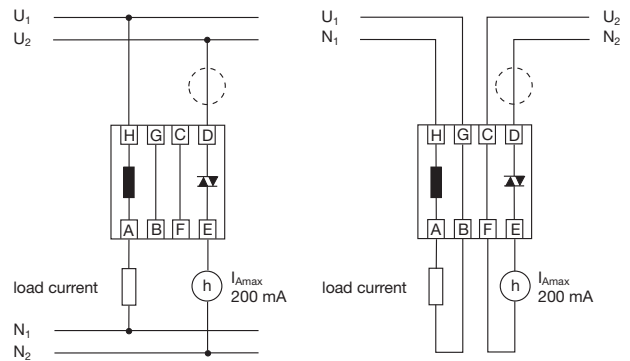

If no physical isolation is required, the monitoring circuit and the output circuit may be fed by the same power supply. The elapsed-hour meter may be installed either before, or after, the triac.

### Output circuit DC 60 V

(e.g. check-back signalling for PLC systems)

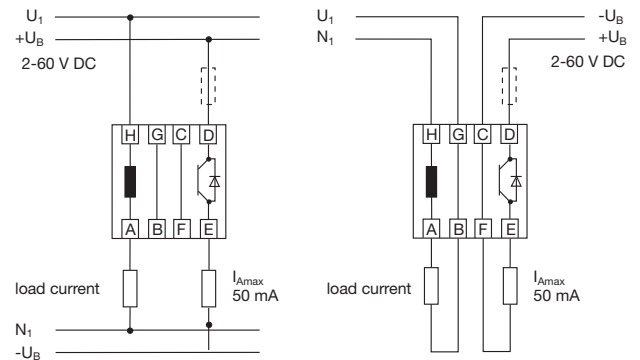

Check-back signalling may be tapped either before, or after, the transistor.