

Description

The E-T-A Solid State Remote Power Controller E-1072-100 is a double pole electronic switching amplifier suitable for resistive and inductive loads (solenoids, magnetic brakes etc.) as well as for lamp loads and capacitive loads.

The double pole electronic switching output eliminates inadvertent start-up or dangerous machine movements as may arise upon a ground fault in systems with ungrounded power supply ('IT systems') (see Machinery Directive 98/37/EG or EN 60204 part 1, para. 9.4.3.1).

Typical applications

- Two pole actuator switching for machinery and plants.
- Monitoring of the electrical functionability of these loads.
- In-rush current limitation of lamp and capacitive loads.
- Protection of load circuit cables.
- ON and fault indication (by LEDs or RED trip button) and signalling (via potential-free auxiliary contacts).
- Two pole physical isolation upon overload or when tripped manually.

Features

- PLC controllable electronic switching amplifier (max. 3 A) with additional protective and control functions for DC 24 V loads (e.g. solenoids, magnetic brakes, electromagnetic clutches, monitoring and indicator lamps).
- Overload and short-circuit proof double pole switching output with in-rush current and short-circuit limitation.
- Electronic disconnection upon
 - an overload in the load circuit,
 - short-circuit in the load (load+/load-, load+/-U_B, and load+/-U_B), followed by 2-pole isolation of the load circuit (via relay contacts).
- Control input "In/Ctrl" with control current indication (YELLOW LED).
- "O.K." and availability indication (GREEN LED).
- Short-circuit and overload indication (fault indication F and RED LED).
- "Err1" group fault signalisation – all faults will be signalled:
 - wire breakage in the load circuit
 - earth fault at switching output
 - internal faults
 - overload or short circuit in the load circuit
- "Err2" fault signalisation:
 - only overload or short circuit in the load circuit
 - reset required
- Integral protection against reverse polarity and overvoltage for the control and load circuit.

Ordering information

Type No.	
E-1072	Solid State Remote Power Controller SSRPC
	100 (trips only with overload or short circuit)
	Voltage rating of load
	DC 24 V
	Current rating
	3 A
E-1072	- 100 - DC 24 V - 3 A



E-1072-100

Technical data (T_{ambient} = 25 °C, U_B = DC 24 V)

Voltage rating U _N	DC 24 V
Operating voltage U _B	DC 19.2...36 V
Current rating I _N	max. 3 A
Current consumption I ₀ (U _S = "0")	typically 24 mA
Power loss P _{max} (I _N =3 A)	typically 3.5 W
Residual ripple for all voltages	max. 5 % (3 phase bridge)
Reverse polarity protection U _B	integral -> fault release, LEDs not lighting Caution: Ensure free travel of actuator button.
Insulation voltage	AC 500 V (control circuit, load circuit, fault indication "Err1" and "Err2")
Load Circuit	
Load output (term. 31-term. 32)	two pole switching output (minus and plus switching), MOS transistors
Max. load data	DC 24 V/3 A (no derating over the entire temperature range!)
Min. load data	DC 24 V / 50 mA (wire break threshold 30 mA)
Voltage drop at I _N	typically 0.9 V (R _i typically 300 mΩ)
Switch times (t _{on} / t _{off})	typically 2 ms (resistive load)
Overload disconnection	approx 1.15 x I _N (typically 3.45 A)
Trip time (I _{load} = 2 x I _N)	typically 400 ms
Short-circuit current I _K	typically 12 A current limitation
Trip time (upon I _K)	typically 50 ms, 2-pole isolation of load circuit after approx. 200 ms -> RED LED indicates, fault indication F "Err1" and "Err2"
Wire break monitoring	with the load switched on or off; RED LED "Error" lighted, group fault signalisation "Err1" (U _S = "0") wire break threshold R _{load} > 10 kΩ (U _S = "1") minimum current I _{load} < 30 mA
Supervision of load circuit	with the load switched on, the load current is monitored via the two switching outputs GREEN LED indicates (OK signal), I _{load} > 30 mA
Leakage current (U _S = "0")	typically 1 mA
Free-wheeling circuitry	integral
Load current measurement	no isolation of load circuit required as a 0.1 Ω±1 % measuring shunt is integral with the device. Measurement by voltmeter terminal 33 - terminal 34 (100 mV = 1 A)
Isolation of load circuit	2-pole by relay contacts - by manual release of RED button - approx. 200 ms after electronic tripping due to overload or short circuit ("OFF")

Technical data (cont'd)

Control circuit	
Control "In/Ctrl"	internal low-level signal relay in control input (with integral free-wheeling diode)
Control voltage U_S	"0" : 0...2.4 V "1" : 18...32 V
Control voltage I_S	typically 5...10 mA
Switching frequency f_{max}	10 Hz
Control signal (U_S "1")	"In/Ctrl" YELLOW LED lights with I_S flowing
Protection	reverse polarity protection (diode), overvoltage protection (varistor)

Fault indication

"Err1"	group fault signalisation potential-free relay contact N/O, DC 30 V/0.5 mA...1 A
Fault indication "Err1"	- wire breakage in the load circuit - load current < 30 mA - other faults (ground fault in load circuit or internal fault) - overload/short circuit (= "Err2") - LED RED "Error" lighted - LED GREEN "O.K." not lighted - relay contact "Err1" closed
Signal delay	typically 600 ms

"Err2"	fault indication potential-free auxiliary contact, make contact N/O, DC 30 V/0.5 mA...1 A
Fault indication »Err2«	- overload or short circuit in the load circuit - LED RED "Error" lighted - LED GREEN "O.K." not lighted - relay contact "Err1" closed - auxiliary contact "Err2" closed - RED button "OFF" - reset required - load circuit isolated 2-pole - manual release "OFF" - reverse polarity of U_B (LEDs not indicating)
Signal delay	typically 200 ms

General data

Ambient Temperature	0...+50 °C (without condensation)
Storage temperature	-20 ...+70 °C
Terminals	COMBICON MSTBO 2.5/4 1x2.5 mm ² max. 16-pole Some are double terminals -> loop-through possibility (continuous load max. 6 A)
Back-up protection for SSRPC	circuit breaker for plus line (term. 41/42): depending on power supply capacity and number of loop-through arrangements, max. 12 A (= max. continuous load of the COMBICON terminals)
Housing material	PA 66-FR
Mounting	symmetric rail to EN 50022-35
Vibration	3 g, to IEC 68-2-6 test Fc
Degree of protection (IEC 529/DIN 40050)	IP20 housing
EMC	IP20 terminals emitted interference EN 50081-1 interference suppression EN 61000-6-2
Mounting dimensions	22.5 x 99 x 122 mm (w x h x d)
Mass	approx. 130 g

Status matrix

Operating status	Fault-free operation		Short circuit/overload in load circuit	Wire break in load circuit		Other faults
	"0"	"1"		"0"	"1"	
Control input	"0"	"1"	"1"	"0"	"1"	"0"
Load output	OFF 2-pole non-conductive	ON 2-pole conductive	OFF 2-pole non-conductive	OFF 2-pole non-conductive	ON 2-pole non-conductive	OFF 2-pole non-conductive
Load circuit isolated 2 pole (via relay contacts)	no	no	yes	no	no	no

Indication

YELLOW LED "In/Ctrl"	0	1	1	0	1	0
GREEN LED "O.K."	1	1	0	0	0	0
RED LED "Error"	0	0	1	1	1	1
relay contacts "Err1"	open	open	closed	closed	closed	closed
auxiliary contacts "Err2"	open	open	closed	open	open	open
RED operating/reset button	ON	ON	OFF ("OFF")	ON	ON	ON
Remark	availability	load: > 30 mA < 3 A	RED button to be reset			ground fault in load circuit or internal fault

1 = LED lights
0 = LED does not light

Operating modes at:

- reverse polarity: indication of fault "Err2"; LEDs not illuminated!
- manual release "OFF" (RED button out): indication of fault "Err1" and "Err2", additionally lighted LED RED "Error".
- with $U_B = 0$ V: not fault indication "Err1".

Typical time/current characteristics ($T_A = 25$ °C)

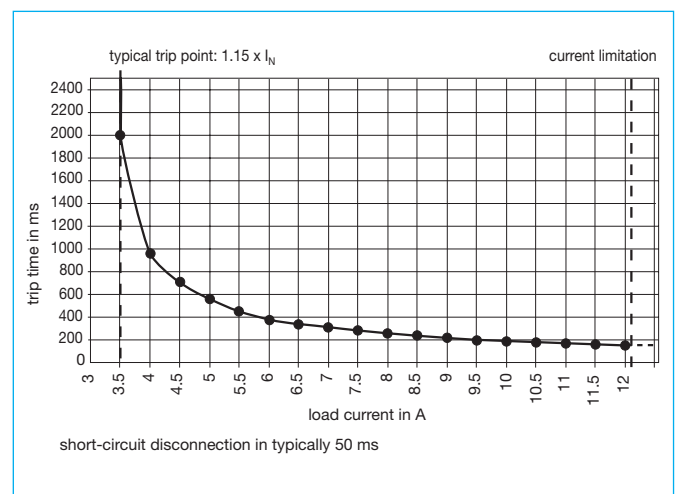

Dimensions

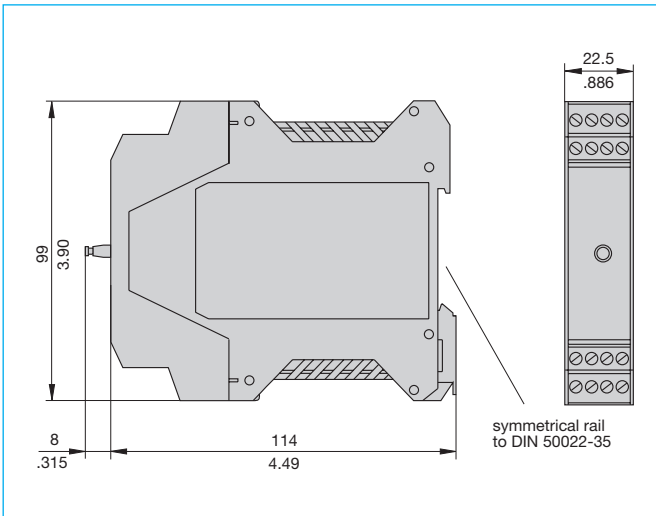

This is a metric design and millimeter dimensions take precedence ($\frac{\text{mm}}{\text{inch}}$)

Connection diagram

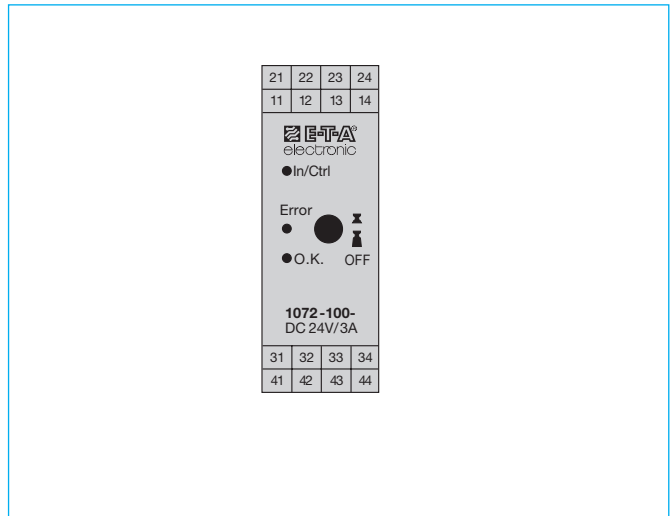

Basic circuit diagram

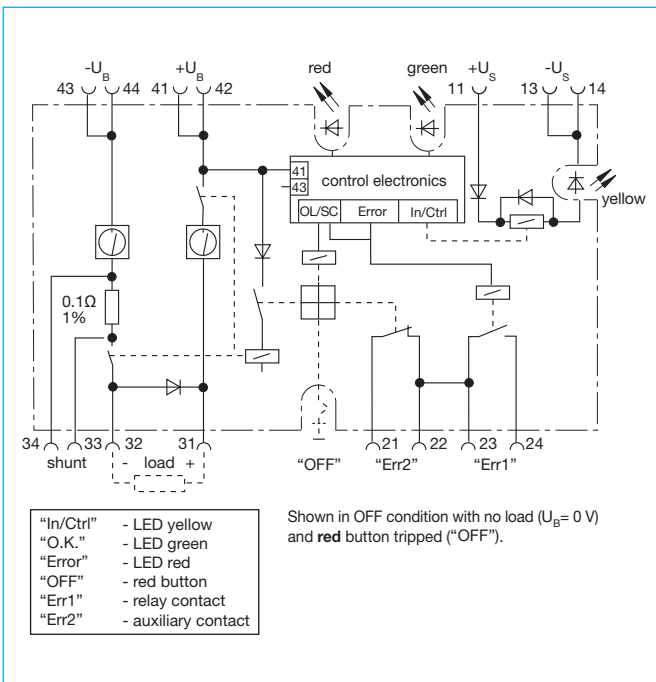

Terminal selection

Level	Terminal	Remark
1	11	+U _S (control voltage plus) DC 18...32 V
1	13 / 14	-U _S (control voltage minus)
1	12	not use
2	21	"Err2" fault indication OL/SC (signal contact NO)
2	22 / 23	joint terminal "Err1", "Err2" C
2	24	"Err1" group fault indication (relay contact NO)
3	31	load (+) DC 24 V / max. 3 A
3	32	load (-)
3	33 / 34	load current measurement by voltmeter (shunt 0.1 Ω ± 1 % integral with device, 100 mV ≙ 1 A) term. 33: shunt+ / term. 34: shunt-
4	41 / 42	+U _B (operating voltage plus) DC 19.2...36 V
4	43 / 44	-U _B (operating voltage minus)

Top side

21	22	23	24	LEVEL 2 (fault indication)
11	12	13	14	LEVEL 1 (control input)
31	32	33	34	LEVEL 3 (load circuit)
41	42	43	44	LEVEL 4 (voltage supply)

Cable side (bottom)

All dimensions without tolerances are for reference only. In the interest of improved design, performance and cost effectiveness the right to make changes in these specifications without notice is reserved. Product markings may not be exactly as the ordering codes. Errors and omissions excepted.