

## Description

The E-T-A Solid State Remote Power Controller E-1071-353 is a double relay with protective function both for resistive and inductive **DC 24 V** loads. It is particularly suitable to control upward/downward and forward/backward movements. **Failure of one channel will also cause the other channel to disconnect.**

## Typical applications

- Valve timing gears for forward/backward or upward/downward movements (overlapping operation is possible)
- Parallel circuits which must be completely disconnected upon failure of one of the circuits.

## Features

- Small double relay with protective function
- Overcurrent and short-circuit proof outputs
- Two pole physical isolation of both channels
  - approx. 5 s after electronic disconnection of a fault
  - by manual release
- Both part units are disconnected upon the isolator tripping
- Current load of each unit: max. 3 A; total current max. 4 A
- Electrical isolation between control and load circuit by means of opto coupler
- Control current indication by RED LED
- Load current indication by GREEN LED
- With auxiliary contact (fault indication)
- Temperature disconnection

## Ordering information

Type No.	
E-1071	SSRPC
	353 double unit
	Voltage rating of load
	DC 24 V
	Current rating
	3 A / 3 A
E-1071 - 353 - DC 24 V - 3 A / 3 A ordering example	



**E-1071-353**

## Technical data ( $T_{\text{ambient}} = 25\text{ °C}$ , $U_S = \text{DC } 24\text{ V}$ )

Voltage rating $U_N$	DC 24 V
Operating voltage $U_S$	DC 20...48 V
Current rating $I_N$	3 A/3 A (2 A + 2 A)
Current consumption ( $U_S = \text{DC } 24\text{ V}$ , $U_{\text{Contr}} = \text{"0"}$ )	typically 30 mA
Residual ripple for all voltages	max. 5 % (3 phase bridge)
Reverse polarity protection	$U_S$ (terminals 1 and 2)
Physical isolation	2-pole <ul style="list-style-type: none"> <li>- by manual circuit breaker release</li> <li>- approx. 5 s after overload disconnection</li> <li>- upon thermal response (approx. +130 °C)</li> </ul>
<b>Load circuits (I/II)</b>	
Load output	NPN transistor, minus switching
Load rating	DC 24 V/0.2...3 A per channel with parallel duty of both channels: max. 4 A (e. g. 2 A + 2 A)
Voltage drop at $I_N$	max. 1.8 V
Overload disconnection	approx. $1.1 \times I_N$
Storage time $t_S$ (at $2 \times I_N$ )	typically 20 ms (see storage time curve)
Short-circuit limitation	approx. $2.5 \times I_N$
Short-circuit response delay	approx. 4 $\mu\text{s}$
Load current monitoring	GREEN LED lights at $I_{\text{load}} > 0.1\text{ A}$
Current measuring terminals	3 x 4 mm dia. (shunt $0.1\ \Omega \pm 1\%$ )
Leakage current ( $U_{\text{Contr}} = \text{"0"}$ )	max. 3 mA
Free-wheeling diode	integral
<b>Control circuits (I/II)</b>	
Control	opto coupler in control input
Control voltage $U_{\text{Contr}}$	"0" = 0...5 V "1" = 8.5...35 V
Control current $I_{\text{Contr}}$	typically 5 mA
Switching frequency $f_{\text{max}}$	100 Hz
Control signal ( $U_{\text{Contr}} = \text{"1"}$ )	RED LED lights ( $I_{\text{Contr}}$ flowing)
Protection	reverse polarity protection (diode)
<b>Signal output</b>	
Fault indication	auxiliary contact (N/O) <ul style="list-style-type: none"> <li>- max. DC 30 V/3 A</li> <li>- physically isolated</li> <li>- closed when the circuit breaker has tripped</li> </ul>
<b>General data</b>	
Ambient temperature	0...+60 °C (without condensation)
Terminals	screw terminals 2 x 2.5 mm <sup>2</sup> to DIN 46288
Housing	clamping plate: polycarbonate GV, blue cover: polycarbonate, black symmetric rail to EN 50022-35
Mounting	to UL 94: V = 0; VDE 0304: grade 1
Self-extinguishing properties	IP20 housing, terminals
Degree of protection (IEC 529/DIN 40050)	
Mounting dimensions	45 x 74 x 128 mm
Mass	approx. 320 g

## Technical description

Under normal operating conditions, the E-T-A SSRPC E-1071-353 allows the connection or disconnection of the load outputs of two channels independent of each other.

### Control circuits (I/II)

The control current flows through the LED and the opto coupler immediately a voltage higher than 8.5 V ( $\hat{=}$  control signal "1") is applied at the input terminals (6 and 7, or 10 and 7). The opto coupler transmits the signal to the load circuit, at the same time switching the load transistor on. This signal is transmitted as a status signal to all monitoring circuits. The input protection diode protects the control voltage from incorrect polarization. Control current limitation is provided by a constant current diode.

### Load circuits (I/II)

The load circuit is switched ON or OFF according to the control signal ("0" or "1"), with electronic circuits monitoring the load circuit for faults such as overload or short-circuit. Should one of these faults occur, the monitoring circuitry will immediately react, causing the load transistor to disconnect and the circuit breaker to trip. Transistor disconnection occurs according to the storage time characteristics. The storage time increases noise immunity avoiding disconnection of non-harmful peaks such as those caused by inrush currents from lamp load connection. Storage time is not a constant quantity but is inversely proportional to the overcurrent factor.

After expiration of the storage time (see diagram) the load circuit transistor will become non-conductive. After approx. 5 s the isolator will switch off so as to disconnect the two load circuits. The common auxiliary contact closes signalling the fault. After removal of the fault, the SSRPC can be reactivated by pushing the isolator button.

### Status outputs

Status indication is provided by 4 LEDs (2 x RED, 2 x GREEN).

#### RED LED

ON indication (I/II)

The red LED indicates when the control voltage is higher than 8.5 V, with control current flowing.

#### GREEN LED

Current flow indication (I/II)

The green LED indicates when the load current is above 0.1 A.

Faults such as too high a resistance, wire break, poor contact, or overload/short-circuit, are available when only the red LED indicates.

The SSRPC E-1071-353 includes three current measuring terminals (4 mm dia.) on the front. These terminals provide for load current measurement in terms of voltage drop at the 0.1  $\Omega$  shunt in the load circuit (I/II).

## Storage time characteristic curve $t_s$ ( $T_A = 25^\circ\text{C}$ )

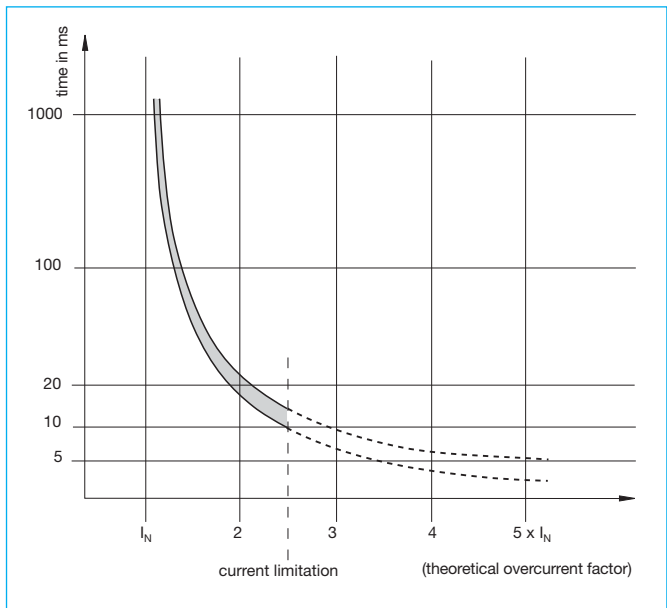

## Operating modes

Operating status	Fault-free operation		Short-circuit on the load	Wire break	
	"0"	"1"		"0"	"1"
Control input	"0"	"1"	"1"	"0"	"1"
RED LED - control current	0	1	1	0	1
GREEN LED - Load current monitoring	0	1	0	0	0
Auxiliary contact	open	open	closed	open	open
Remarks	load OFF	load ON	both load circuits disconnected		

1 - LED indicates

0 - LED does not indicate

## Dimensions

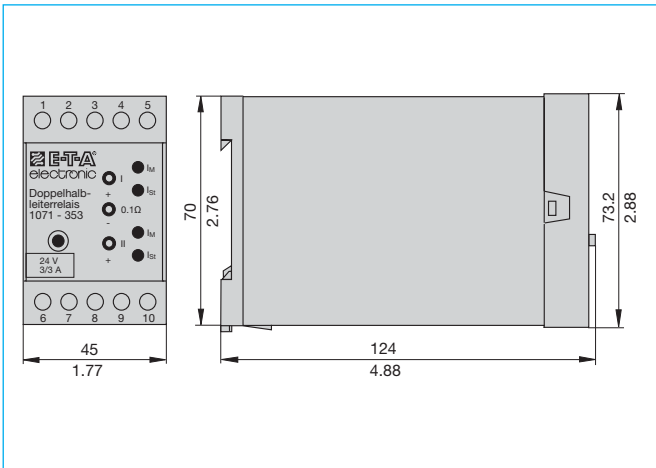

This is a metric design and millimeter dimensions take precedence ( $\frac{\text{mm}}{\text{inch}}$ )

## Basic circuit diagram

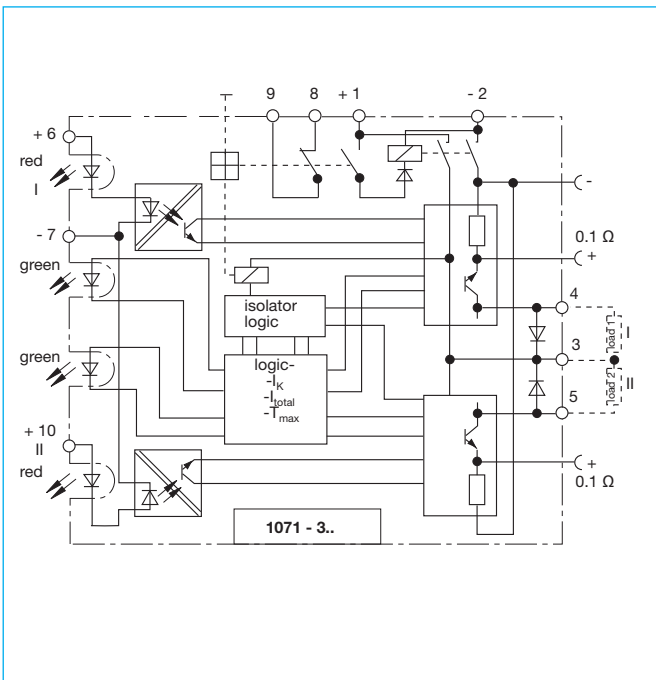

## Terminal selection

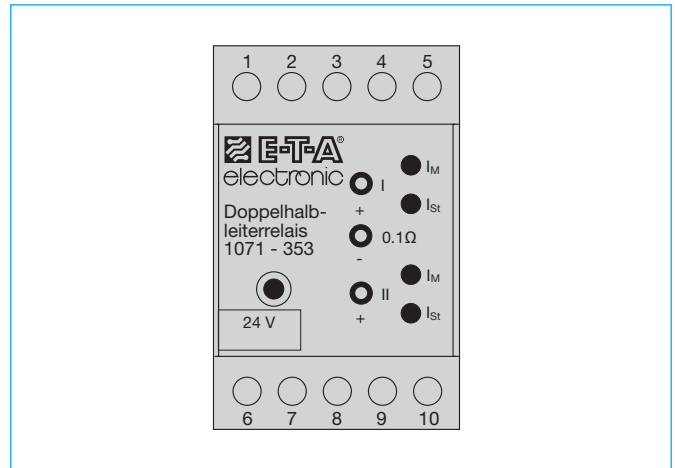

## Terminal

- 1 operating voltage +  $U_S$ : DC 20...48 V
- 2 operating voltage -  $U_S$
- 3 load (+) (carrying plus potential)  
**CAUTION:** Do not connect to GND/- $U_S$
- 4 load I (-)
- 5 load II (-)
- 6 control voltage I +  $U_{Contr}$ : max. DC 35 V
- 7 control voltage I, II -  $U_{Contr}$
- 8 auxiliary contact
- 9 auxiliary contact
- 10 auxiliary voltage II +  $U_{Contr}$ : max. DC 35 V