

Description

Single pole, miniaturised, aircraft style thermal circuit breaker with tease-free, trip-free, snap action mechanism and push/pull on/off manual actuation (M-type TO CBE to EN 60934). An indicator band on the push button clearly shows the tripped/off position. Threadneck panel mounted, available in metric and US (MS 3320) configurations. Advanced two-chamber design contributes to fail-safe operation. Temperature compensated from -55° to +125 °C, with optional auxiliary contacts, and fully approved for use on a wide range of aircraft and equipment. Full specification ensures suitability for the most demanding applications. For three pole version see type 583.

Typical applications

Aircraft systems and equipment (fixed wing and helicopters); other extra low voltage wiring applications; defence equipment; communications systems.

Standard current ratings and typical volt drop values

| Current rating (A) | Volt drop (mV) | Current rating (A) | Volt drop (mV) |
|--------------------|----------------|--------------------|----------------|
| 1 | 750 | 10 | 190 |
| 2 | 520 | 15 | 190 |
| 2.5 | 400 | 20 | 200 |
| 3 | 360 | 25 | 170 |
| 4 | 350 | 30 | 160 |
| 5 | 260 | 35 | 150 |
| 7.5 | 230 | | |

Approvals

| Authority | Voltage ratings | Current ratings |
|--------------------|-------------------------------|----------------------|
| LN 29886 | | |
| VG 95345 T06 | | |
| MS 3320, MS 3320 V | | |
| QPL | | |
| UL | AC 250 V, 50/60 Hz DC 75 V | 1...25 A 1...35 A |



Technical data

| | | |
|---|---|--------------------------|
| Voltage rating | AC 115 V (400 Hz); DC 28 V (higher voltage ratings upon request) | |
| Current rating range | 1...35 A | |
| Auxiliary circuit | 0.5 A, DC 28 V | |
| Typical life | 20,000 operations mechanical or 10,000 operations at I_N (≤ 25 A) 5,000 operations at I_N (30 + 35 A) | |
| Ambient temperature | -55...+125 °C (-67...+257 °F) | |
| Insulation co-ordination (IEC 60664 and 60664A) | rated impulse withstand voltage 1.5 kV | pollution degree 3 |
| Dielectric strength (IEC 60664 and 60664A) | test voltage operating area main to aux. circuit | AC 1,500 V AC 1,500 V |
| Insulation resistance | > 100 M Ω (DC 500 V) | |
| Interrupting capacity I_{cn} | AC 115 V (400 Hz): ≤ 4 A 1,000 A 5 A 2,000 A 7.5...35 A 2,500 A DC 28 V: 1...25 A 6,000 A 30 + 35 A 4,000 A | |
| Degree of protection (IEC 60529/DIN 40050) | operating area IP40 terminal area IP00 | |
| Vibration (sinusoidal) | 15 g (70-2000 Hz), ± 0.76 mm (5-70 Hz) to VG 95210, sheet 19, IEC 60068-2-6, test Fc/ISO 7137 | |
| Vibration (random) | 16.4 g rms, 0.2 g ² /Hz ± 1.5 dB to VG 95210, sheet 29, ISO 7137 | |
| Acceleration | 17 g, to ISO 2669 | |
| Shock | 75 g (11 ms) to VG 95210, sheet 28, IEC 60068-2-27, test Ea/ISO 7137 | |
| Corrosion | 96 hours at 5 % salt mist, severity A 48 hours at 20 % salt mist, severity B to VG 95210, sheet 2, IEC 60068-2-11, test Ka/ISO 7137 | |
| Humidity | 240 hours at 95 % RH, to VG 95210, sheet 7, IEC 60068-2-3, test C/ISO 7137 | |
| Explosion | to VG 95210, sheet 10, MIL-STD-202, meth. 109 | |
| Altitude | $\leq 25,000$ m above sea level | |
| Mass | max. 29 g with auxiliary contact max. 25 g without auxiliary contact | |
| Weight reduction through aluminium threadneck: approx. 3 g | | |

All dimensions without tolerances are for reference only. In the interest of improved design, performance and cost effectiveness the right to make changes in these specifications without notice is reserved. Product markings may not be exactly as the ordering codes. Errors and omissions excepted.

Ordering information

| | |
|--|---|
| Type No. | |
| 483 | single pole, with temperature compensation |
| Mounting | |
| G | threadneck panel mounting, standard |
| L | threadneck panel mounting, extended push button |
| V | threadneck panel mounting, high vibration performance |
| Threadneck design | |
| 1 | M12x1x6.4x8.8 dia. with mounting plate (aux. contact version) |
| 2 | 15/32-32UNx6.4x7.8 dia. (without aux. contact) |
| 3 | MJ12x6.4x8.8 dia. (without aux. contact) |
| 4 | M12x1x6.4x8.8 dia. (without aux. contact) |
| 5 | 7/16-32UNx6.4x7.8 dia. (without aux. contact) |
| 6 | M12x1x9.4x8.8 dia. (without aux. contact) |
| 7 | 7/16-32 UNx6.4x7.8 dia. with mounting plate (aux. contact version) |
| 8 | as 483-G1...but with aluminium threadneck (only mounting -G and aux. contact versions S1, S5) |
| Hardware for threadneck (washers) | |
| 0 | without hardware |
| 1 | wave washer 12/15 - mounted |
| 2 | mounted washer 12.1/17.2 - mounted |
| 3 | mounted washer 11.3/14.9 - mounted (threadneck design 5, 7 only) |
| 4 | mounted washer 12/15 - mounted |
| 5 | tooth washer 12.1/17.2, bulk shipped |
| Hardware for threadneck (nuts) | |
| 0 | without hardware |
| 1 | hex nut M12x1 (threadneck design 1, 4, 6 only) |
| 2 | hex nut 15/32-32UN (threadneck design 2 only) |
| 3 | hex nut 7/16-32UN (threadneck design 5, 7 only) |
| 4 | hex nut M12x1, aluminium, fitted (threadneck design 8 only) |
| 5 | hex nut MJ12x1 (only with threadneck design 3) |
| 6 | hex nut M12x1, bulk shipped (threadneck design 1, 4, 6) |
| Terminal design (main terminals) | |
| K screws terminals with metric thread | |
| 1 | K14 (M4, MJ4) |
| J screw terminals with inch thread | |
| 1 | J14 (8-32UNC-2B) |
| 2 | J17 (8-32UNC-2B) |
| 3 | J25 (6-32UNC-2B) |
| Characteristic curve | |
| M1 | thermal, 1.15-1.38 I _N |
| Terminal screws | |
| A | Phillips screw M4x6 |
| B | Phillips screw 8-32UNC-2Ax6 (MS 51957-41) |
| C | Phillips screw 6-32UNC-2Ax6 (MS 51957-26) |
| D | slotted flat head screw M4x6 |
| E | hex screw with Phillips head 8-32UNC-3A-9.5 |
| K | hex screw with Phillips head 8-32UNC-3Ax7.6 |
| L | Phillips screw MJ4x6 |
| M | as "K" but bulk shipped |
| Z | without accessories |
| Terminal washers | |
| 0 | without lock washer |
| 1 | lock washer B4 |
| 2 | lock washer 4.3 (MS 35338-137) |
| 3 | lock washer B4 and washer 4.4/9.5 |
| 4 | lock washer 3.7 (MS 35338-136) |
| 5 | lock washer 4.3/9 |
| Auxiliary contact | |
| S0 | without auxiliary contact |
| S1 | with auxiliary contact (N/C) connector to EN3155-016M2018, size 20 |
| S5 | with polarized auxiliary contact (N/C) |
| Barrier | |
| Z | without barrier (standard) |
| Colour of the push button | |
| blank: black (standard) (e. g. 7.5) | |
| A | green (e. g. 7.5) |
| G | green, marking to EN (e. g. 7 1/2) |
| N | black, marking to EN (e. g. 7 1/2) |
| Current ratings | |
| 1...35 A | |
| 483 - G 4 1 1 - K 1 M1 - A 1 S0 Z . - 5 A ordering example | |

Ordering information for approved devices

483-G411-K1M1-A1S0ZN

Metric threadneck M12x1 and terminal design -K14 (M4x6), listed by the German Materialamt der Bundeswehr to VG 95345 T06.

483-G111-K1M1-A1S1ZN

Metric threadneck M12x1 and terminal design -K14 (M4x6) and auxiliary contact -Si, listed by the German Materialamt der Bundeswehr to VG 95345 T06.

483-G533-J1M1-B2S0ZN (MS 3320)

Threadneck size 7/16-32UNSx6.4 and terminal design -J14 (inch thread 8-32), approved to MS 3320.

483-V533-J1M1-B2S0ZN (MS 3320-V)

Threadneck size 7/16-32UNSx6.4 and terminal design -J14 (inch thread 8-32), approved to MS 3320-V.

483-G533-J3M1-C4S0Z

Threadneck size 7/16-32UNSx6.4 and terminal design -J25 (inch thread 6-32), listed by the German Materialamt der Bundeswehr to VG 95345, part 6.

483-G814-K1M1-A1S1ZN

Aluminium threadneck M12x1x6.4x8.8 dia.

Internal connection diagrams

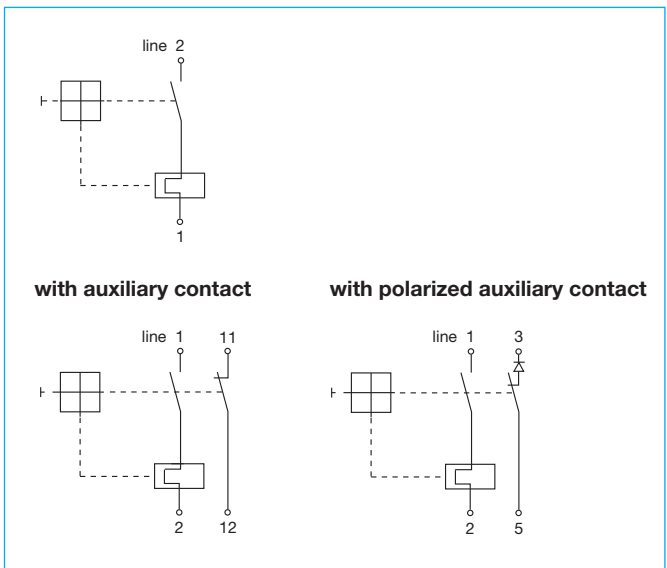

Dimensions 483-G411-K1M1-A1S0ZN (VG 95345 T06)

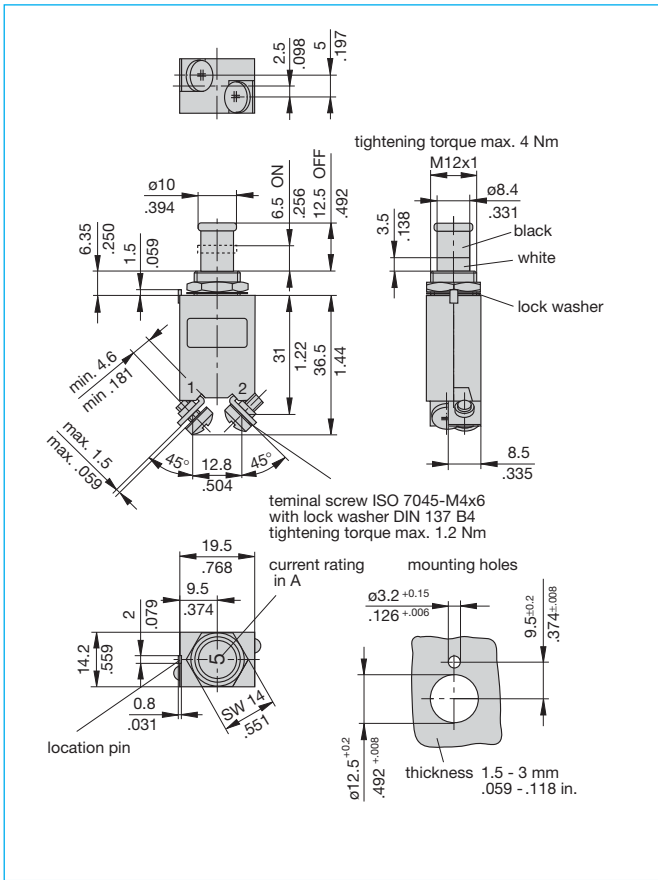

Dimensions 483-G111-K1M1-A1S1ZN (VG 95345 T06)

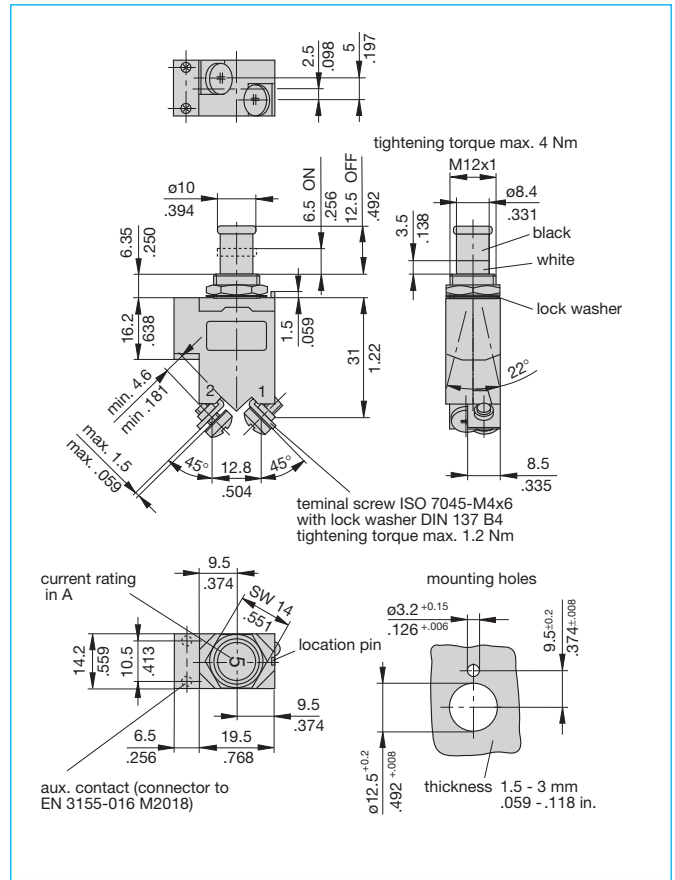

Dimensions 483-G533-J1M1-B2S0ZN (MS 3320)

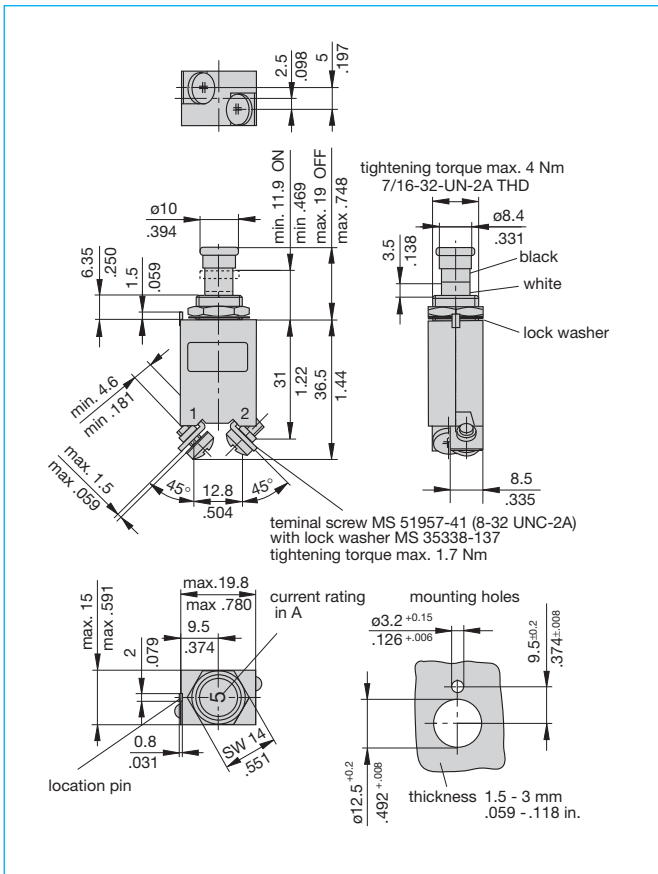

Mounting

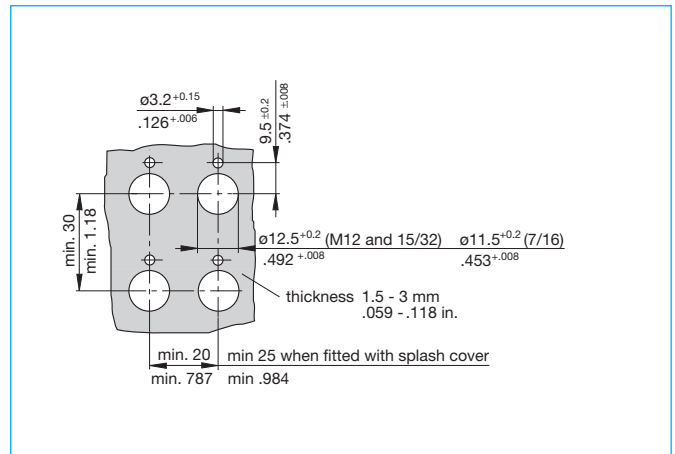

This is a metric design and millimeter dimensions take precedence (mm/inch)

Other main terminal and threadneck designs

Terminal design -J2

Terminal distances to:

- MS 14 105 (a, b)
- MS 14 153 (a, b)
- MS 22 073 (a)
- MS 22 074 (a)
- MS 25 244 (a)
- MS 25 373 (a, b)

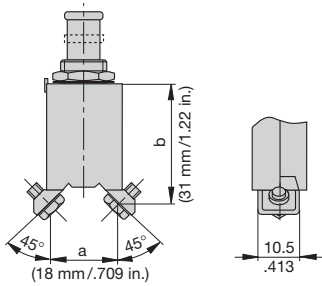

Terminal design -J3

Terminal distances to:

- MS 26 574 (a, b)

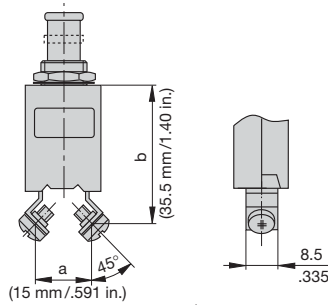

Mounting -G6

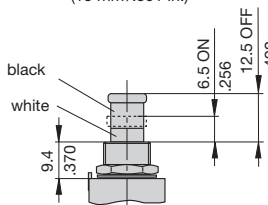

Mounting -L2/5/7

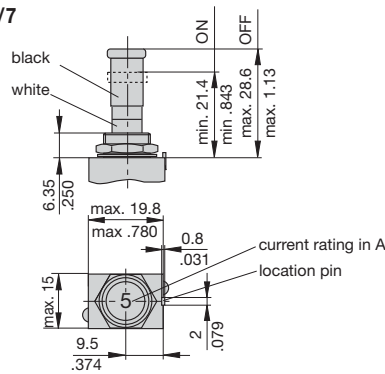

Accessories

Identification collar to be snapped on the push button

- Y 307 004 01 black
- Y 307 004 02 white
- Y 307 004 03 red
- Y 307 004 04 green
- Y 307 004 05 blue

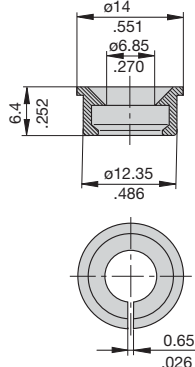

Typical time/current characteristics

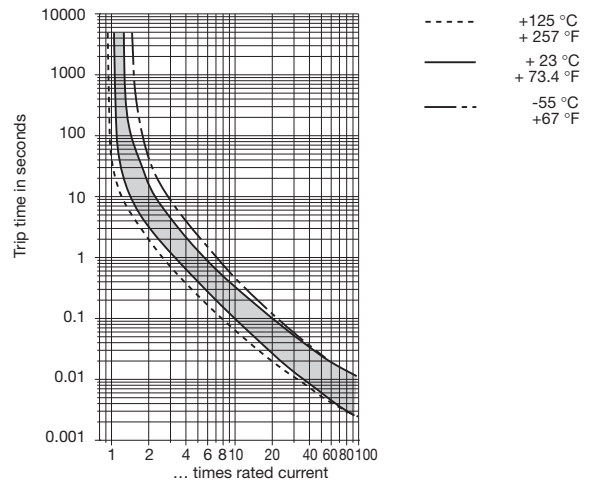

Accessories

Splash cover/hex nut assembly with O ring (IP66 and IP67)
(approved to VG 95345, T23)

- X 200 801 08 nickel plated nut, transparent cover
- X 200 801 03 matt black finish nut, black cover
- X 200 801 09 matt black finish nut 7/16-32, black cover

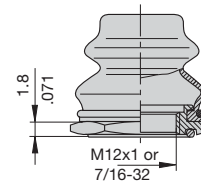

Splash cover/hex nut assembly with O ring (IP54)

(approved to VG 95345, T23)

- X 200 802 01 nickel plated nut
- X 200 802 02 matt black finish nut

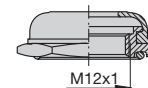

Actuator extension (black) to be fitted on the push button
(approved to VG 95345, T23)

- X 200 803 01

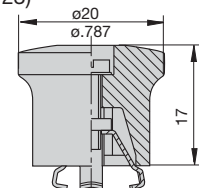

Lock out ring to block the push button in OFF position

- Y 307 005 01 red
- Y 307 005 02 black

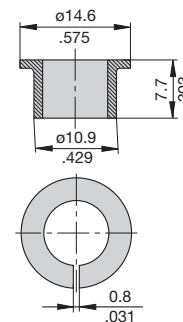

This is a metric design and millimeter dimensions take precedence (mm / inch)