

Description

Single pole thermal-magnetic circuit breaker with trip-free mechanism and toggle actuation. Two-chamber construction with cascade contact arrangement to provide high voltage DC capability and high switching performance.

Designed for plug-in mounting in distribution rail X2210-S0606J (see section 7) or terminal blocks 23-P10-Si-202005 and 63-P10-Si-202005. Approved to CBE standard EN 60934 (IEC 60934).

Typical applications

Communications systems, power supplies, process control equipment.

Ordering information

Type No.	2210 thermal-magnetic circuit breaker, toggle operated
Mounting	S291 socket or panel mounting with M3 thread
Terminal design	P9 blade terminals, for distribution rails X2210-S.. and X2210-K..
Characteristic curve	M2 medium delay
Style	410033 single pole with two chambers (one chamber protected only), 1 break contact Si1
Current ratings	1...25 A
2210 - S291 - P9 M2 - 410033 - 10 A ordering example	

Standard current ratings and typical internal resistance values

Current rating (A)	Internal resistance (Ω)
1	1.10
2	0.25
3	0.13
4	0.07
6	0.04
8	0.02
10	0.02
16	< 0.02
25*	< 0.02

*80% I_N continuous load

Approvals

Authority	Voltage ratings	Current ratings
GL, VDE (EN 60934)	AC 250 V; DC 65 V	1...25 A



2210-S291-P9M2-410033-...A

Technical data

Voltage rating	AC 250 V; DC 65 V
Current rating range	1...25 A
Auxiliary circuit	1 A, AC 240 V/DC 65 V
Typical life	> 10,000 operations at 1 x I _N > 20,000 operations mechanical
Ambient temperature	-30°C...+60 °C (-22...+140 °F)
Insulation co-ordination (IEC 60664 and 60664A)	rated impulse withstand voltage 2.5 kV pollution degree 2 reinforced insulation in operating area
Dielectric strength (IEC 60664 and 60664A)	test voltage operating area AC 3,000 V main to aux. circuit AC 1,500 V
Insulation resistance	> 100 MΩ (DC 500 V)
Interrupting capacity I _{cn}	AC 250 V 1,000 A cosφ = 0.8 DC 65 V 2,000 A L/R = 4 ms
Degree of protection (IEC 60529/DIN 40050)	operating area IP30 terminal area IP00
Vibration	5 g (57-500 Hz), ± 0.38 mm (10-57 Hz); to IEC 60068-2-6, test Fc 10 frequency cycles/axis
Shock	25 g (11ms) directions 1, 2, 3, 4, 5 20 g (11 ms) direction 6 to IEC 60068-2-27, test Ea
Corrosion	96 hours in 5 % salt mist to IEC 60068-2-11, test Ka
Humidity	240 hours at 95 % RH to IEC 60068-2-78, test Cab
Mass	approx. 80 g

Description

Single pole thermal-magnetic circuit breaker with trip-free mechanism and toggle actuation. Two-chamber construction with cascade contact arrangement to provide high voltage DC capability and high switching performance.

Designed for plug-in mounting in distribution rail X2210-S0606J (see section 7) or terminal blocks 23-P10-Si-202005 and 63-P10-Si-202005. Approved to CBE standard EN 60934 (IEC 60934).

Typical applications

Communications systems, power supplies, process control equipment.

Ordering information

Type No.	2210	thermal-magnetic circuit breaker, toggle operated
Mounting	S291	socket or panel mounting with M3 thread
Terminal design	P9	blade terminals, for distribution rails X2210-S.. and X2210-K..
Characteristic curve	M2	medium delay
Style	410005	single pole with two chambers (protected), 1 break contact Si1
Current ratings	10 A	0.4...25 A
2210 - S291 - P9 M2 - 410005 - 10 A ordering example		

Standard current ratings and typical internal resistance values

Current rating (A)	Internal resistance (Ω)	Current rating (A)	Internal resistance (Ω)
0.4	6.87	6	0.09
0.65	2.96	8	0.03
1	1.84	10	0.03
1.6	0.75	12	0.02
2	0.50	16	< 0.02
2.5	0.35	20*	< 0.02
3	0.25	25*	< 0.02
4	0.15	*80 % I _N continuous load	

Approvals

Authority	Voltage ratings	Current ratings
GL, VDE (EN 60934)	AC 250 V; DC 65 V	0.4...25A



2210-S291-P9M2-410005-...A

Technical data

Voltage rating	AC 250 V; DC 65 V	
Current rating range	0.4...25 A	
Auxiliary circuit	1 A, AC 240 V/DC 65 V	
Typical life	> 10,000 operations at 1 x I _N > 20,000 operations mechanical	
Ambient temperature	-30°C...+60 °C (-22...+140 °F)	
Insulation co-ordination (IEC 60664 and 60664A)	rated impulse withstand voltage 2.5 kV	pollution degree 2
	reinforced insulation in operating area	
Dielectric strength (IEC 60664 and 60664A)	test voltage operating area AC 3,000 V main to aux. circuit AC 1,500 V	
Insulation resistance	> 100 MΩ (DC 500 V)	
Interrupting capacity I _{cn}	AC 250 V 0.4...1 A 1.6...25 A DC 65 V 0.4...4 A 6...25 A	cosφ = 0.8 self-limiting 2,000 A L/R = 4 ms self-limiting 3,500 A
Degree of protection (IEC 60529/DIN 40050)	operating area IP30 terminal area IP00	
Vibration	5 g (57-500 Hz), ± 0.38 mm (10-57 Hz); to IEC 60068-2-6, test Fc 10 frequency cycles/axis	
Shock	25 g (11ms) directions 1, 2, 3, 4, 5 20 g (11 ms) direction 6 to IEC 60068-2-27, test Ea	
Corrosion	96 hours in 5 % salt mist to IEC 60068-2-11, test Ka	
Humidity	240 hours at 95 % RH to IEC 60068-2-78, test Cab	
Mass	approx. 80 g	

Dimensions

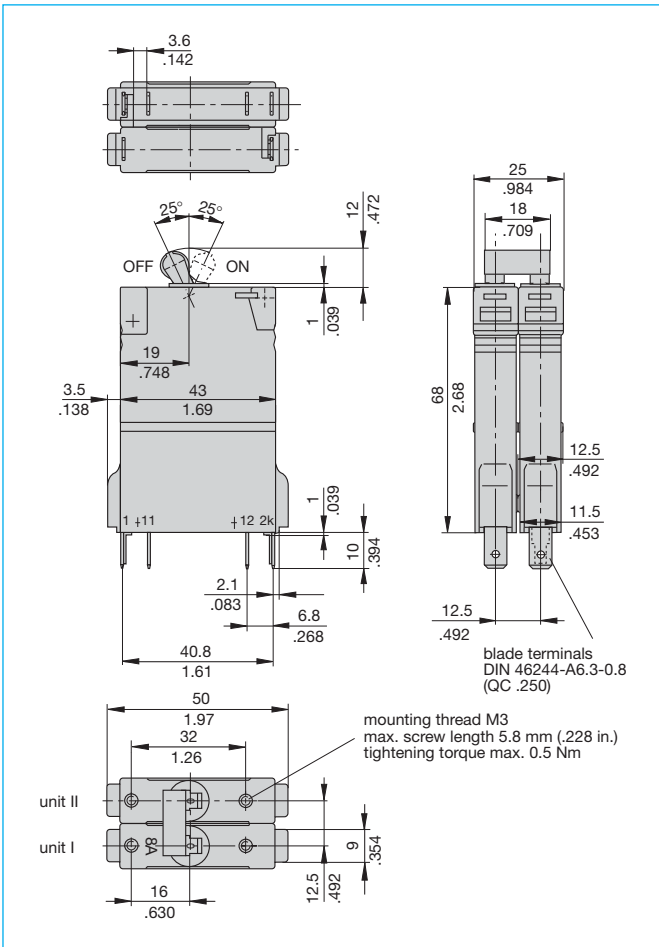

Internal connection diagrams

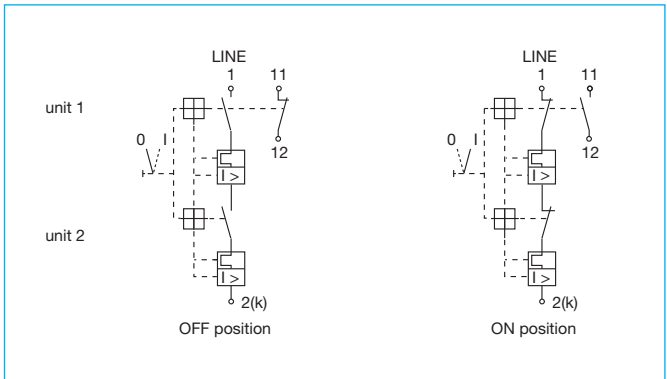

Shock directions

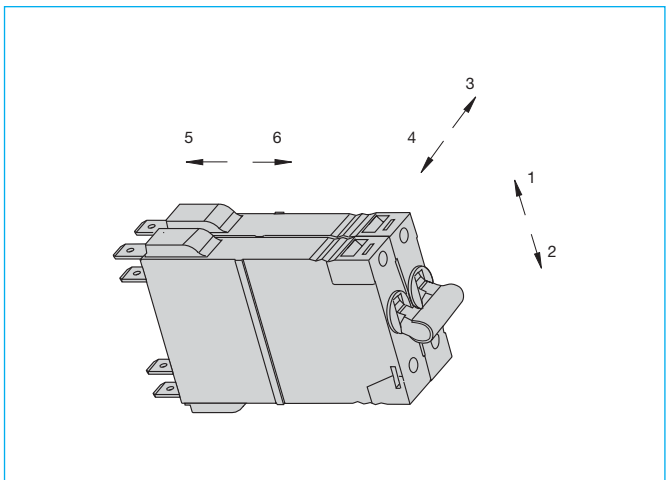

Installation drawing

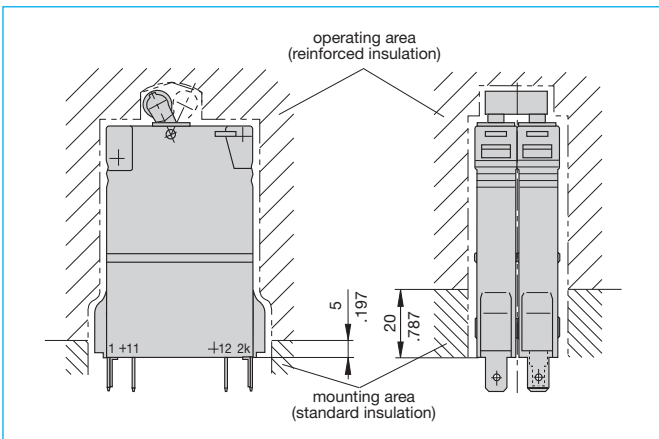

Selective back-up fuses

Voltage rating	Interrupting capacity	Selective to	
		NH fuse rating	Current rating of 2210-S291-P2M2-410005
60 V DC	3,500 A	35 A	≤ 6 A
		50 A	≤ 12 A
		63 A	≤ 20 A
		80 A	≤ 25 A
		100 A	≤ 25 A
250 V AC	2,000 A	35 A	≤ 3 A
		50 A	≤ 8 A
		63 A	≤ 20 A
		80 A	≤ 25 A
		100 A	≤ 25 A

NH fuse according to VDE 0636, part 21 (IEC 269)
NH fuse = low voltage power fuse

Typical time/current characteristics

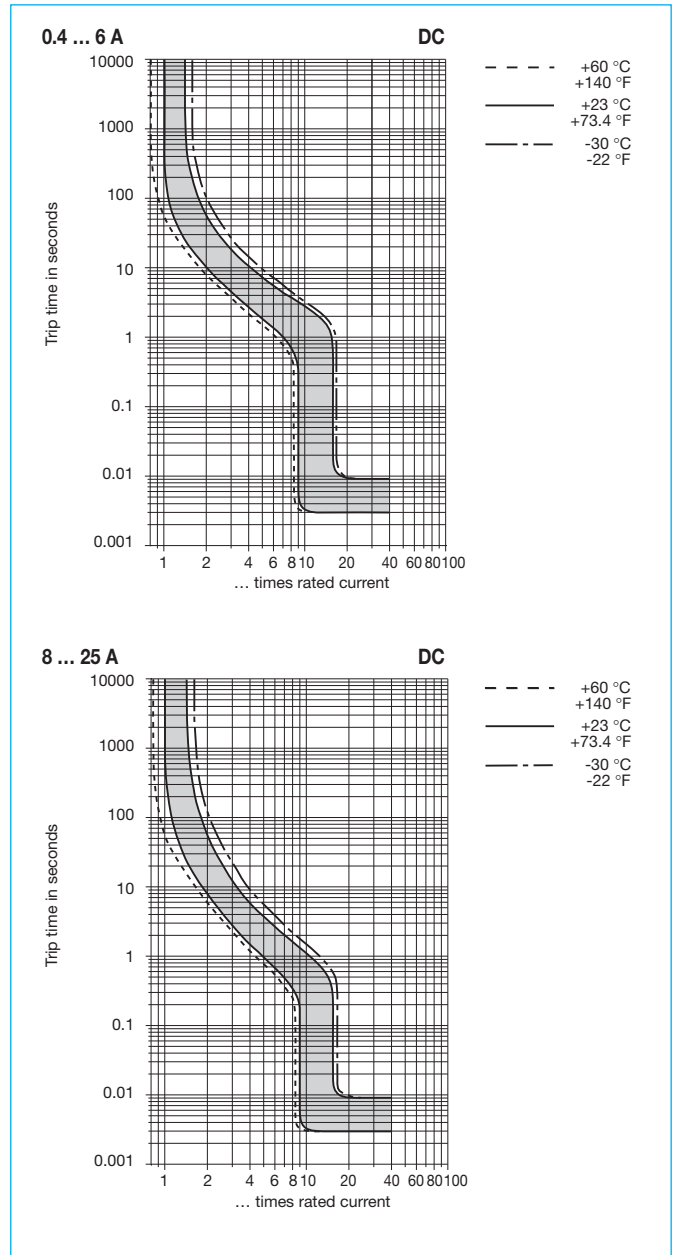
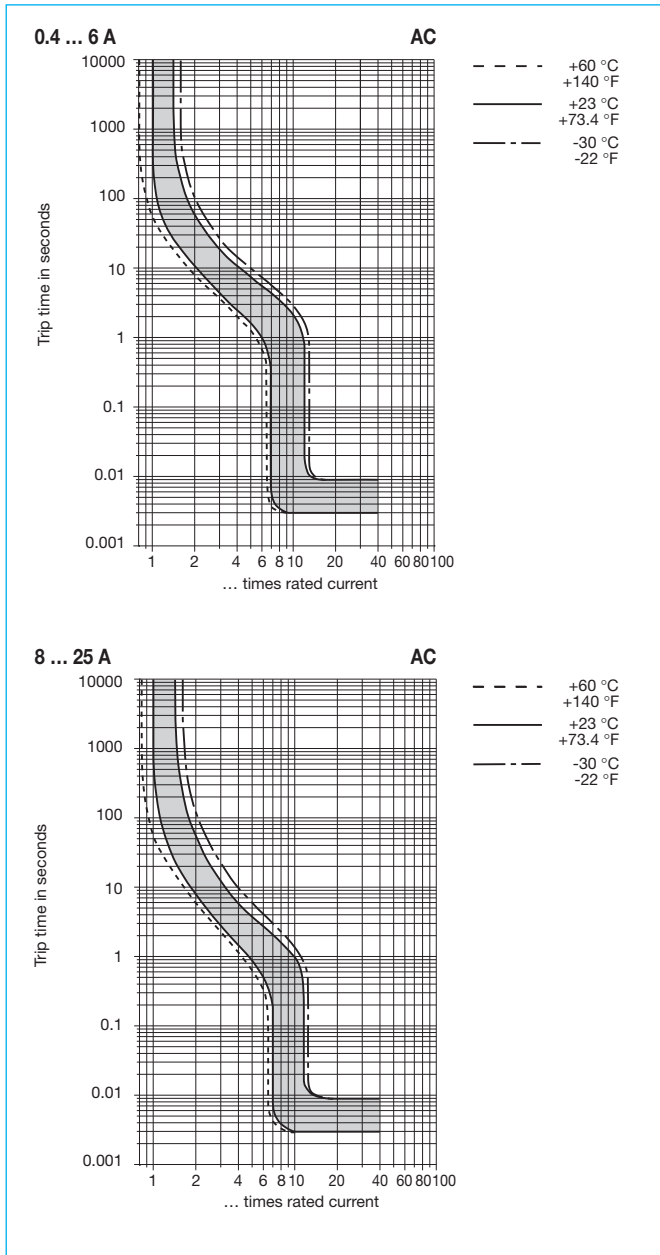

The time/current characteristic curve depends on the ambient temperature prevailing. In order to eliminate nuisance tripping, please multiply the circuit breaker current ratings by the derating factor shown below. See also section 9 – Technical information.

Ambient temperature °F	-22	-4	+14	+32	+73.4	+86	+104	+122	+140
°C	-30	-20	-10	0	+23	+30	+40	+50	+60
Derating factor	0.76	0.79	0.83	0.88	1	1.04	1.11	1.19	1.29

Accessories

Mounting sockets 23-P10-Si-202005

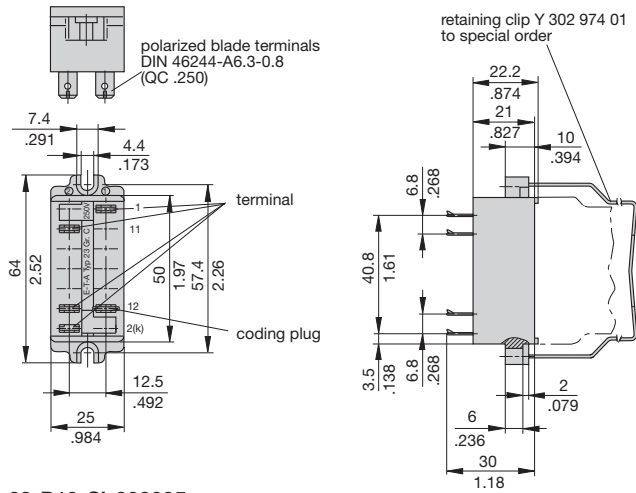

63-P10-Si-202005

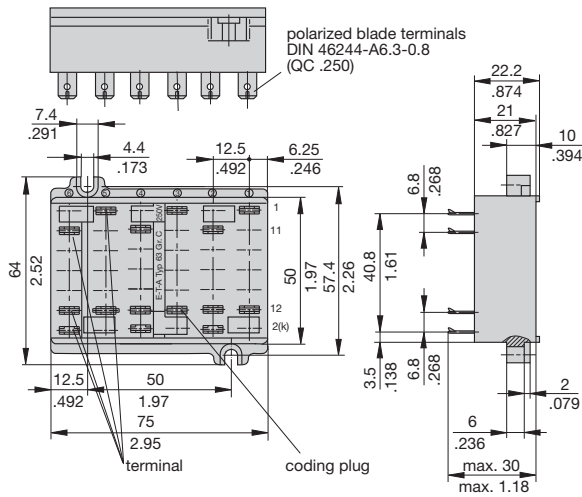

Distribution rail X2210-S06... see section 7.

This is a metric design and millimeter dimensions take precedence ($\frac{\text{mm}}{\text{inch}}$)

All dimensions without tolerances are for reference only. In the interest of improved design, performance and cost effectiveness the right to make changes in these specifications without notice is reserved. Product markings may not be exactly as the ordering codes. Errors and omissions excepted.