

Description

Module 17plus is a power distribution system for use with

- E-T-A Circuit Breakers type 2210-S..., 3600-..., 3900-...
- E-T-A Electronic Circuit Breaker ESS20, ESX10
- Solid State Remote Power Controller E-1048-7...

Each module accommodates two single pole plug-in circuit breakers with an individual housing width of only 12.5 mm and fits onto all industry standard mounting rails.

The two-way modules can be mounted side-by-side to provide as many ways as required with a terminal block fitted at each end. A distribution busbar can be fitted on the supply side of the modules, but each pole of multipole circuit breakers must be individually connected.

Electrical connections are by means of screwless spring loaded terminals.

Suitable electro-mechanical circuit breakers have integral make and break auxiliary contacts. Depending on the application these may be used for either single or group signalisation. For group signalisation, the make contacts (which open in the event of a fault) are connected in series to the terminal blocks of the modules. The module is designed to accommodate a probe for series connection continuity tests. When multipole circuit breakers are fitted auxiliary contacts are required for each pole.

Single signalisation is achieved through use of the break contacts (which close in the event of failure) connected in parallel by means of terminals on each module.

Both types of signalisation (single and group signalisation) are available at the same time if the circuit breakers used provide auxiliary contacts (please note when ordering).

The signalling circuitry between modules is automatically connected when the modules are mounted side-by-side (linked together).



17plus

Technical data

Connection Spring-loaded terminals for rigid wires and flexible cables with and without wire end ferrules. Please use appropriate screw driver size (SD) for removing the spring loaded terminals.

cable	cross section of connecting cable	screw driver	stripped length
Line feed (1)	1.5-10 mm ²	3 (1.0 x 5.5)	12 mm
Load output (2)	0.25-4 mm ²	1 (0.6 x 3.5)	12 mm
Signalisation terminals (11, 13, 14)	0.25-2.5 mm ²	1 (0,6 x 3,5)	10 mm
Signalisation terminal (12)	0.25-1.5 mm ²	0 (0.4 x 2.5)	9 mm

diameter of test socket ≤ 2 mm ø

Voltage rating
(without circuit breaker): AC 250 V; 3 AC 433 V; DC 65 V

Current rating (without circuit breaker)

Line feed (1)	50 A
Load output (2)	25 A
Signalisation Feed (11) (ground with electronic components)	10 A
Single output (12)	1 A
Group signal (13-14)	1 A

Caution: When several devices are mounted together, each should carry only max. 80 % ($I_N \leq 16 A$) or max. 65 % ($I_N > 16 A$) of its rating.

Internal resistances (without circuit breaker)

Line/load (1-2)	≤ 5 mΩ
Signalisation (11-12)	≤ 9 mΩ (+ 2 mΩ per additional module)
Group signal (13-14)	≤ 8 mΩ (+ 5 mΩ per additional module)

Vibration 5 g (57-500 Hz) ± 0.38 mm (10-57 Hz), to IEC 60068-2-6, test Fc, 10 frequency cycles/axis

Shock 25 g (11 ms) to IEC 60068-2-27, test Ea, 11 ms half sine

Corrosion 96 hours at 5 % salt mist, to IEC 60068-2-11, test Ka

Humidity 240 hours at 95 % RH to IEC 60068-2-78, test Cab

Dielectric strength

between main circuits (without busbar):	1,500 V
main circuit to auxiliary circuit:	1,500 V
between auxiliary circuits:	1,500 V

Mass: Module 17plus (centre piece) approx. 85 g
terminal blocks (pair) approx. 30 g

Ordering information

17PLUS-Q02-00	Module 17plus, centre piece, two-way
17PLUS-QA0-LR	one each left- and right-side terminal block for supply feed from the side by means of screw terminal

Technical data of:	please see:
Circuit Breaker 2210-S, 3600, 3900	product group 2
Electronic Circuit Breaker ESS20, ESX10	product group 5
Solid State Remote Power Controller E-1048-7..	product group 6

Approvals

Authority	Voltage ratings	Current ratings
UL 60950	AC 250 V; DC 80 V	50 A

Dimensions

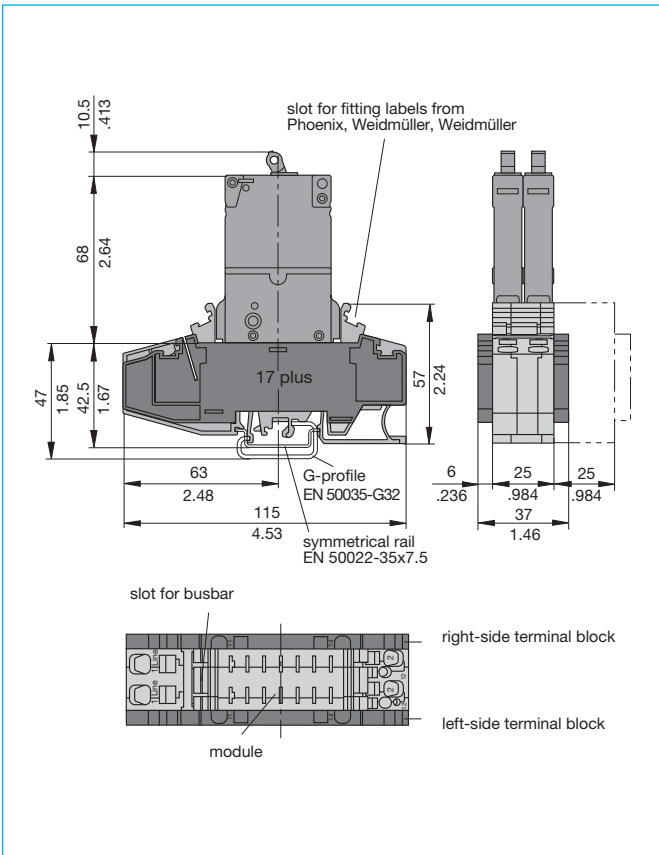

Installation example

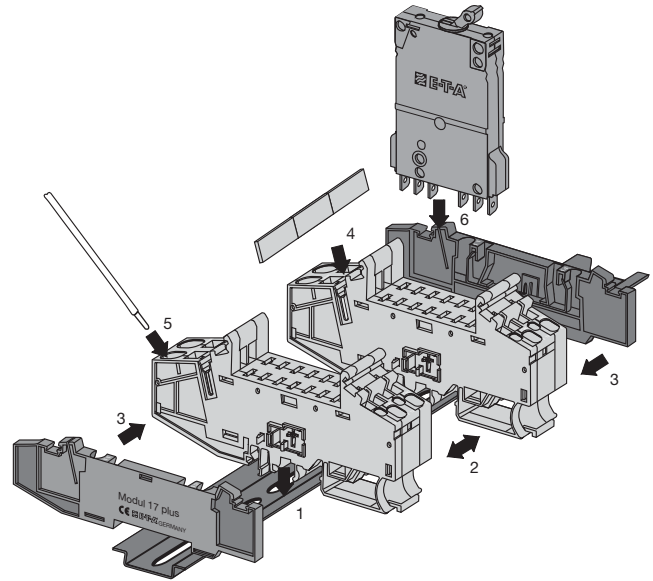

Installation:

- 1 Clip modules onto DIN rails.
- 2 Push modules together (side-by-side).
- 3 Snap on right-side and left-side terminal blocks.
- 4 Cut busbar to required length and fit on supply side of the modules.
- 5 Connect line feed with spring-loaded terminals.
- 6 Plug in circuit breakers.

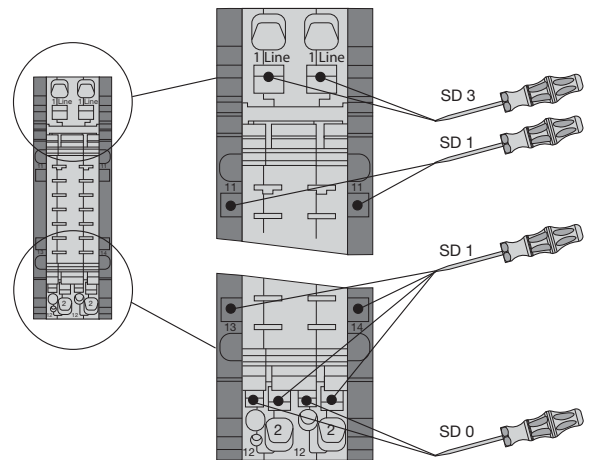

Connection and disconnection of cables with screw driver

Connection diagram

Example for circuit breaker types 2210, 3600, 3900

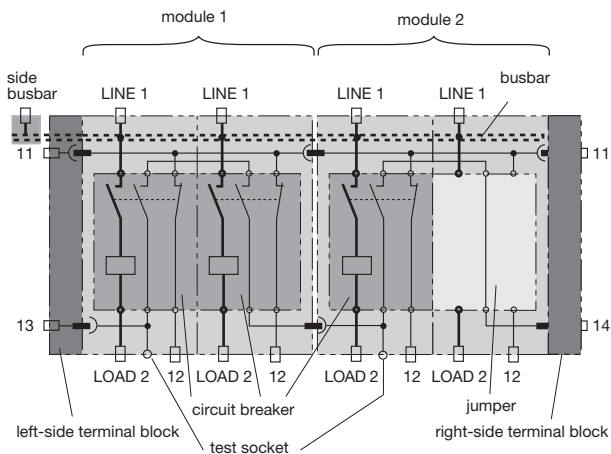

- 13, 14 terminals for group signalisation
- 11 feed for single signalisation
- 12 terminal for single signalisation

For connection diagram for electronic circuit breakers and components please see relevant data sheets of types ESS20, ESS21, E-1048-7..

Module 17plus for electronic overcurrent protection

For technical data, dimensions, mounting examples, schematic diagrams and connection diagrams of

- ESS20-0... please see product group 5
- ESS20-1... please see product group 5
- ESX10 please see product group 5
- E-1048-7... please see product group 6

This is a metric design and millimeter dimensions take precedence (mm/inch)

Accessories

Busbar 32 A

X 222 005 01 blue insulation, 500 mm/19.68 in.
X 222 005 02 red insulation, 500 mm/19.68 in.
X 222 005 03 grey insulation, 500 mm/19.68 in.
 "up to 32 A continuous load"

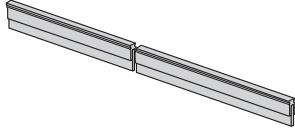

Busbar 50 A

Y 307 016 01 non-insulated, 500 mm/19.68 in.
 "up to 50 A continuous load;
 plugged in completely, protected against brush contact"

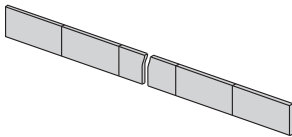

Busbar 50 A

Y 307 016 11 non-insulated, 500 mm/19.68 in.
 "up to 50 A continuous load"

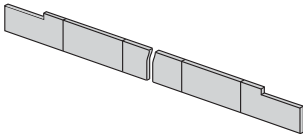

End bracket
X 222 004 01

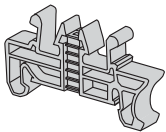

Screw terminal for busbar
X 211 156 01 non insulated
 (up to 35 mm²)

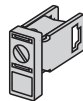

Retaining clip for circuit breaker 3600/3900
 recommended for fitting the devices
Y 300 581 11

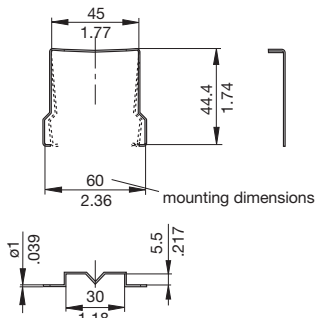

Retaining clip for circuit breaker 2210
 recommended for fitting single pole devices
Y 302 974 21

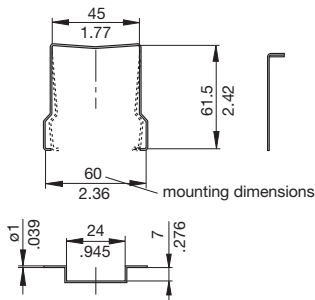

Retaining clip Y 308 792 01

recommended for tight fit of types
 ESX10 / E-1048-S6xx / SB-S11-P1-xx
 and terminal blocks type 17 and 17plus

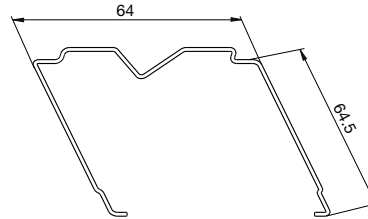

Retaining clip Y 307 754 01

recommended for tight fit of types
 ESS20 / ESX10

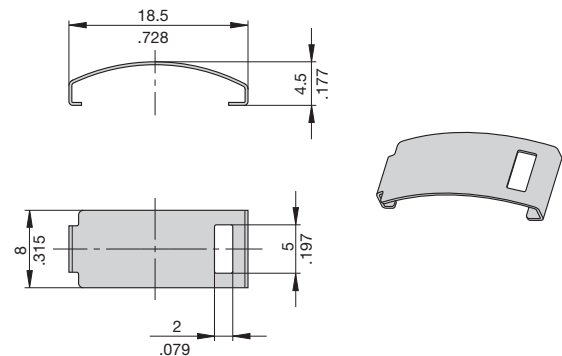

Jumper
SB-S11-P1-01-1-1A

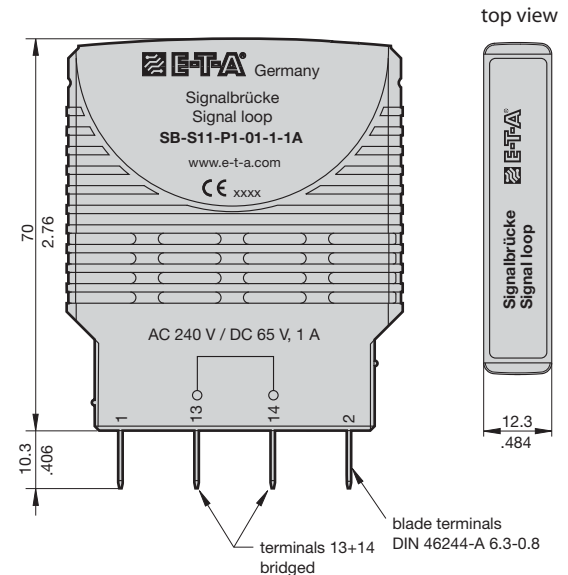

Labels
 marking area 6 x 10 mm
 (ordering unit 10 pcs = 1 strip)
Y 307 942 61

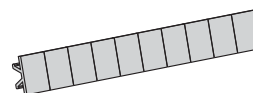

All dimensions without tolerances are for reference only. In the interest of improved design, performance and cost effectiveness the right to make changes in these specifications without notice is reserved. Product markings may not be exactly as the ordering codes. Errors and omissions excepted.

This is a metric design and millimeter dimensions take precedence (mm/inch)

