

Description

Electronic circuit protector type ESX10 is designed to ensure **selective** disconnection of DC 24 V load systems.

DC 24 V power supplies, which are widely used in industry today, will shut down the output in the event of an overload with the result that one faulty load in the system can lead to complete disconnection of all loads. As well as an unidentified failure this also means stoppage of the whole system.

Through **selective** disconnection the ESX10 responds much faster to overload or short circuit conditions than the switch-mode power supply. This is achieved by active current limitation. The ESX10 limits the highest possible current to values between 1.3 to 1.8 times the selected rated current of the circuit protector. Thus it is possible to switch on **capacitive loads of up to 20,000 µF** lamp loads, but they are disconnected only in the event of an overload or short circuit.

For optimal alignment with the characteristics of the application the current rating of the ESX10 can be selected in fixed values from 0.5 A...12 A. Failure and status indication are provided by a multicolour LED and an integral short-circuit-proof status output or a potential-free signal contact.

The ESX10, with a width of only 12.5 mm, can be plugged into the E-T-A power distribution socket Module 17plus ensuring ease of installation and saving space in control cabinets.

Upon detection of overload or short circuit in the load circuit, the MOSFET of the load output will be blocked to interrupt the current flow. The MOSFET and the load circuit may be re-activated via the remote electronic reset input or manually by means of the ON/OFF button. When starting up the system, the load circuit may also be manually disconnected.

Features

- Selective load protection, electronic trip characteristics.
- Active current limitation for safe connection of capacitive loads up to 20,000 µF and on overload/short circuit.
- Current ratings 0.5 A...12 A.
- Reliable overload disconnection with $1.1 \times I_N$ plus, even with long load lines or small cable cross sections (see table 3).
- Manual ON/OFF button (S1).
- Clear status and failure indication through LED, status output SF or Si contact F.
- Electronic reset input RE (option).
- Integral fail-safe element.
- Width per unit only 12.5 mm.
- Plug-in mounting utilising power distribution system Module 17plus or SVSxx optionally (see product group Power distribution systems)
- Additional versions with ATEX approval available.
Marking: Ⓢ II 3G Ex nA IIB T4 Gc X
ESX10-...-E

Please observe separate operating instructions:



ESX10

Technical data ($T_{\text{ambient}} = 25 \text{ °C}$, operating voltage $U_S = \text{DC } 24 \text{ V}$)

Operating data

Operating voltage U_S	DC 24 V (18...32 V)
Current rating I_N	fixed current ratings: 0.5 A, 1 A, 2 A, 3 A, 4 A, 6 A, 8 A, 10 A, 12 A
Closed current I_0	ON condition: typically 20...30 mA depending on signal output
Status indication by means of	<ul style="list-style-type: none"> • multicolour LED: <ul style="list-style-type: none"> GREEN: unit is ON, power-MOSFET is switched on - status output SF ON, supplies +DC 24 V ORANGE: in the event of overload or short circuit until electronic disconnection RED: <ul style="list-style-type: none"> - unit electronically disconnected - load circuit/Power-MOSFET OFF OFF: <ul style="list-style-type: none"> - manually switched off (S1 = OFF) or device is dead - undervoltage ($U_S < 8 \text{ V}$) - after switch-on till the end of the delay period • status output SF (option) • potential-free signal contact F (option) • ON/OFF/ condition of switch S1

Load circuit

Load output	Power-MOSFET switching output (high side switch)
Overload disconnection	typically $1.1 \times I_N$ ($1.05...1.35 \times I_N$)
Short-circuit current I_K	active current limitation (see table 1)
Trip time for electronic disconnection	see time/current characteristics typically 3 s at $I_{\text{Load}} > 1.1 \times I_N$ typically 3 s...100 ms at $I_{\text{Load}} > 1.8 \times I_N$ (or $1.5 \times I_N/1.3 \times I_N$)
Temperature disconnection	internal temperature monitoring with electronic disconnection
Low voltage monitoring load output	with hysteresis, no reset necessary load "OFF" at $U_S < 8 \text{ V}$
Starting delay t_{start}	typically 0.5 sec after every switch-on and after applying U_S
Disconnection of load circuit	electronic disconnection
Free-wheeling circuit	external free-wheeling diode recommended with inductive load
Several load outputs must not be connected in parallel	

Technical data ($T_{\text{ambient}} = 25^{\circ}\text{C}$, operating voltage $U_S = \text{DC } 24 \text{ V}$)

Status output SF	ESX10-104/-124
Electrical data	plus-switching signal output, connects U_S to terminal 12 of module 17plus nominal data: DC 24 V / max. 0.2 A (short circuit proof) status output is internally connected to GND with a 10 kOhm resistor
Status OUT	ESX10-104/-106/-124 (signal status OUT), at $U_S = +24 \text{ V}$ $+24 \text{ V} = \text{S1}$ is ON, load output connected through $0\text{V} = \text{S1}$ is ON, load output blocked and/or switch S1 is OFF
Status $\overline{\text{OUT}}$	ESX10-127 (signal status OUT inverted), at $U_S = +24 \text{ V}$ $+24 \text{ V} = \text{S1}$ is ON, load output blocked, red LED lighted $0 \text{ V} = \text{S1}$ is ON, load output connected through and/or switch S1 is in OFF position
OFF condition	0 V level at status output when: <ul style="list-style-type: none"> switch S1 is in ON position, but device is still in switch-on delay switch S1 is OFF, or control signal OFF, device is switched off no operating voltage U_S
Signal output F	ESX10-103/-115/-125
Electrical data	potential-free signal contact max. DC 30 V/0.5 A, min. 10 V/10 mA
ON condition LED green	voltage U_S applied, switch S1 is in ON position no overload, no short circuit
OFF condition LED off	<ul style="list-style-type: none"> device switched off (switch S1 is in OFF position) no voltage U_S applied
Fault condition LED orange	overload condition $> 1.1 \times I_N$ up to electronic disconnection
Fault condition LED red	electronic disconnection upon overload or short circuit device switched off with control signal (switch S1 is in ON position)
ESX10-101	single signal, make contact contact SC/SO-SI open
ESX10-102	single signal, break contact contact SC/SO-SI closed
ESX10-103	group signal change-over contact contact SC-SO open, SC-SI closed
ESX10-105/-106/-115/-125	group signal, make contact contact SC-SO open
Fault	signal output fault conditions: <ul style="list-style-type: none"> no operating voltage U_S ON/OFF switch S1 is in OFF position red LED lighted (electronic disconnection)

Table 1: voltage drop, current limitation, max. load current

current rating I_N	typically voltage drop U_{ON} at I_N	active current limitation (typically)	max. load current at 100 % ON duty	
			$T_U = 40^{\circ}\text{C}$	$T_U = 50^{\circ}\text{C}$
0.5 A	70 mV	$1.8 \times I_N$	0.5 A	0.5 A
1 A	80 mV	$1.8 \times I_N$	1 A	1 A
2 A	130 mV	$1.8 \times I_N$	2 A	2 A
3 A	80 mV	$1.8 \times I_N$	3 A	3 A
4 A	100 mV	$1.8 \times I_N$	4 A	4 A
6 A	130 mV	$1.8 \times I_N$	6 A	5 A
8 A	120 mV	$1.5 \times I_N$	8 A	7 A
10 A	150 mV	$1.5 \times I_N$	10 A	9 A
12 A	180 mV	$1.3 \times I_N$	12 A	10.8 A

Attention: when mounted side-by-side without convection the ESX10-0.. should not carry more than 80 % of its rated load with 100 % ON duty due to thermal effects.

Technical data ($T_{\text{ambient}} = 25^{\circ}\text{C}$, operating voltage $U_S = \text{DC } 24 \text{ V}$)

Reset input RE	ESX10-124/-125
Electrical data	voltage: max. + DC 32 V high $> \text{DC } 8 \text{ V} \leq \text{DC } 32 \text{ V}$ low $\leq \text{DC } 3 \text{ V} > 0 \text{ V}$ power consumption typically 2.6 mA (+DC 24 V) min. pulse duration typically 10 ms
Reset signal RE (= terminal 13,14 or 12 of Module 17plus)	The electronically blocked ESX10-124/-127 may remotely be reset via an external momentary switch due to the falling edge of a +24 V pulse. The reset signal will be fed in terminal 13, 14 or 12 of Module 17plus and is internally pre-wired. The reset simultaneously affects all blocked ESX10-124/-127 channels of the power distribution system, all switched on ESX10-124/-127 channels remain unaffected. With type ESX10-125 the reset only affects the device concerned. By connecting the individual terminals 12 of the Module 17plus a joint reset signal for all ESX10-125 may be generated.
Caution: unused slots have to be fitted with jumpers	
Control input IN+	ESX10-115
Electrical data	see reset input RE
Control signal IN+	+24 V level (HIGH): device will be switched on by a remote ON/OFF signal 0 V level (LOW): device will be switched off by a remote ON/OFF signal
Switch S1 ON/OFF	unit can only be switched on with S1 if a HIGH level is applied to IN+
General data	
Fail-safe element:	backup fuse for ESX10 <u>not required</u> because of the integral redundant fail-safe element
Blade terminals	6.3 mm to DIN 46244-A6.3-0.8
Housing	moulded
Mounting	plug-in mounting utilising power distribution system Module 17plus or SVSxx
Ambient temperature	0...+50 °C (without condensation, see EN 60204-1)
Storage temperature	-20...+70 °C
Humidity	96 hrs/95 % RH/40 °C to IEC 60068-2-78, test Cab. climate class 3K3 to EN 60721
Vibration	3 g, test to IEC 60068-2-6 test Fc
Degree of protection	housing: IP30 DIN 40050 terminals: IP00 DIN 40050
EMC (EMC directive, CE logo)	emission: EN 61000-6-3 susceptibility: EN 61000-6-2
Insulation co-ordination (IEC 60934)	0.5 kV/2 pollution degree 2 re-inforced insulation in operating area
dielectric strength	max. DC 32 V (load circuit)
Insulation resistance (OFF condition)	n/a, only electronic disconnection
Approvals	UL 2367, File # E306740 Solid State Overcurrent Protectors UL 508, File # E322549 CSA C22.2 No: 14, File 16186 CE logo
Dimensions (W x H x D)	12.5 x 70 x 60 mm
Mass	approx. 40 g

Ordering configuration for ATEX versions: ...-E

Type No.	
ESX10	Electronic Circuit Protector for DC 24 V applications
Version	
1	standard, without physical isolation in the event of a failure
Signal input	
0	without signal input
1	with control input IN+
2	with reset input RE
Signal outputs	
0	without
3	signal output F (group signal, change-over)
4	status output SF
5	signal output F (group signal, N/O)
Operating voltage	
DC 24 V	rated voltage DC 24 V
Current rating	
0,5...12 A	
Approvals	
E	ATEX
ESX10 -1 0 3 - DC 24 V -6 A E	ordering example

Ordering information

Type No.	
ESX10	Electronic Circuit Protector for DC 24 V applications
Version	
1	standard, without physical isolation in the event of a failure
Signal input	
0	without signal input
1	with control input IN+, only ESX10-115
2	with reset input RE, only ESX10-124
Signal outputs	
0	without, only ESX10-100
3	signal output F (group signal, change-over) only ESX10-103
4	status output SF (+24 V = OK), only ESX10-104, ESX10-124
5	signal output F (group signal, N/O)
Operating voltage	
DC 24 V	rated voltage DC 24 V
Current rating	
0,5 A	
1 A	
2 A	
3 A	
4 A	
6 A	
8 A	
10 A	
12 A	
ESX10 - 1 0 3 - DC 24 V - 6 A	ordering example

Description of ESX10 signal inputs and outputs (wiring diagrams) see next page.

Preferred types

NEW

Preferred types	Standard current ratings (A)							
	1	2	3	4	6	8	10	12
ESX10-103-DC24V	x	x	x	x	x	x	x	x

Please note:

- The user should ensure that the cable cross sections of the relevant load circuit are suitable for the current rating of the ESX10 used.
- Automatic start-up of machinery after shut down must be prevented (Machinery Directive 98/37/EG and EN 60204-1). In the event of a short circuit or overload the load circuit will be disconnected electronically by the ESX10.

Approvals

Authority	Voltage ratings	Current ratings
UL 2367	DC 24 V	0.5...12 A
UL 508	DC 24 V	0.5...12 A
CSA C22.2 No: 14	DC 24 V	0.5...12 A
TÜV Süd/ATEX approval	DC 24 V	0.5...12 A
IEC/EN 60079-0/-14/-15	⊕ II 3G Ex nA IIB T4 Gc X	

Schematic diagram ESX10-124

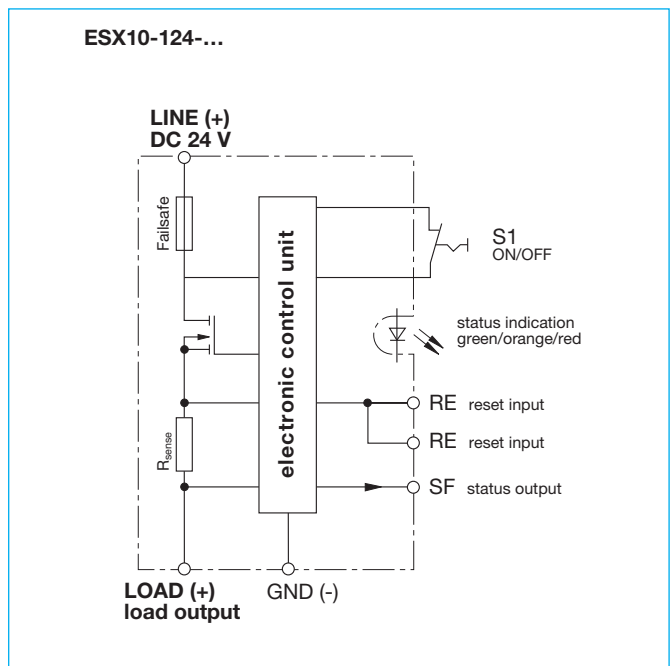

Terminal wiring diagram ESX10-124

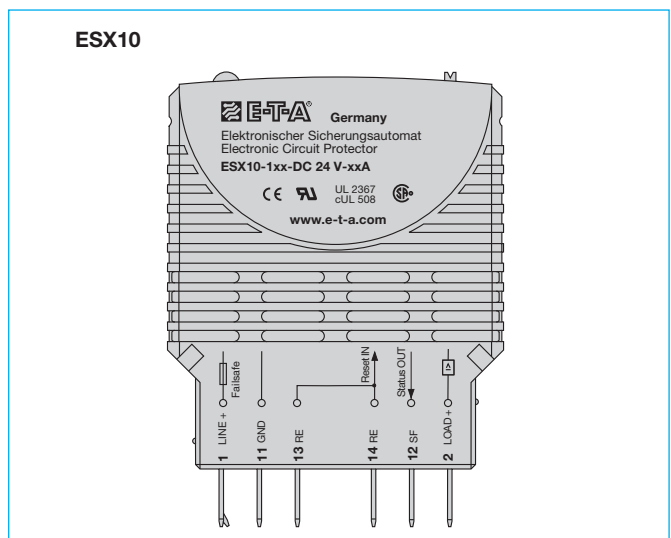

EG-declaration of Conformity for ATEX-version ESX10-TA/-TB-...-E

E-T-A® E-T-A Elektrotechnische Apparate GmbH

EG-Konformitätserklärung Nr. 100.218.1016-01
Declaration of Conformity

Wir **E-T-A Elektrotechnische Apparate GmbH**
Wir (Name des Anbieters / supplier's name)

Industriestrasse 2-8
D-90518 Altdorf
Germany

erklären in alleiniger Verantwortung, dass das Produkt
declare under our sole responsibility that the single pole product

elektronischer Sicherungsautomat
electronic circuit protector

ESX10 (Steckmontage plug-in mounting, DC24V)
ESX10-TA (Hutschienenmontage rail mounting, DC24V)
ESX10-TB (Hutschienenmontage rail mounting, DC24V)

auf das sich diese Erklärung bezieht, mit der/den folgenden
Norm(en) oder normativen Dokument(en) übereinstimmt
to which this declaration relates is in conformity with the following standard(s) or
other normative document(s).

EN 60079-0: 2009, Explosive Atmosphäre - Allgemeine Anforderungen
Explosive atmospheres - General requirements
EN 60079-15: 2011, Explosive Atmosphäre - Geräteschutz durch
Zündschutzart „n“
Explosive atmospheres - Equipment protection by type of protection "n"

gemäß den Bestimmungen der Richtlinie(n)
Following the provisions of Directive(s) (falls zutreffend / if applicable)

94/9/EG ATEX-Richtlinie
94/9/EG ATEX directive

und der bestimmungsgemäßen Verwendung in explosionsgefährdeten
Bereichen entspricht.
and meets the requirements of intended use in explosive areas

II 3G Ex nA IIB T4 Gc X 0°C ≤ T_A ≤ +50°C
für Zone 2 (Gas-Atmosphäre)
for zone 2 (gas atmosphere)

Diese Konformitätserklärung entspricht der Europäischen Norm DIN EN ISO/IEC 17050-1:2010 "Konformitätsbewertung - Konformitätserklärung von Anbietern - Teil 1: Allgemeine Anforderungen" und der internationalen Norm, ISO/IEC 17050-1:2004, Conformity assessment - Supplier's declaration of conformity - Part 1: General requirements.

This Declaration of Conformity is suitable to the European Standard DIN EN ISO/IEC 17050-1:2010 "Conformity assessment - Supplier's declaration of conformity - Part 1: General requirements" and the international Standard ISO/IEC 17050-1:2004, Conformity assessment - Supplier's declaration of conformity - Part 1: General requirements.

D-90518 Altdorf/bei Nürnberg • Germany • Telephone +49 9187 / 10-0 • Facsimile +49 9187 / 10-398

1/2

E-T-A® E-T-A Elektrotechnische Apparate GmbH

Die zugehörige Betriebsanleitung enthält wichtige sicherheitstechnische Hinweise und Vorschriften für die Inbetriebnahme der genannten Geräte gemäß der Richtlinie 94/9/EG (ATEX)
The pertinent user manual holds vital safety-related information and regulations for start-up of the described devices in accordance with directive 94/9/EG (ATEX).

Werden die Produkte in eine übergeordnete Maschine/Anlage eingebaut, so müssen die durch den Einbau entstehenden neuen Risiken durch den Hersteller der neuen Maschine/Anlage beurteilt werden.
Should the products be fitted into a superordinate machine /system, the newly developing risks have to be assessed by the manufacturer of the new machine/system.

Altdorf, 27. Oktober 2011

(Ort und Datum der Ausstellung /
Place and date of issue)

(Name und Unterschrift oder gleichwertige Kennzeichnung des Befugten / name and signature or equivalent of authorized person)

D-90518 Altdorf/bei Nürnberg • Germany • Telephone +49 9187 / 10-0 • Facsimile +49 9187 / 10-398

2/2

Dimensions

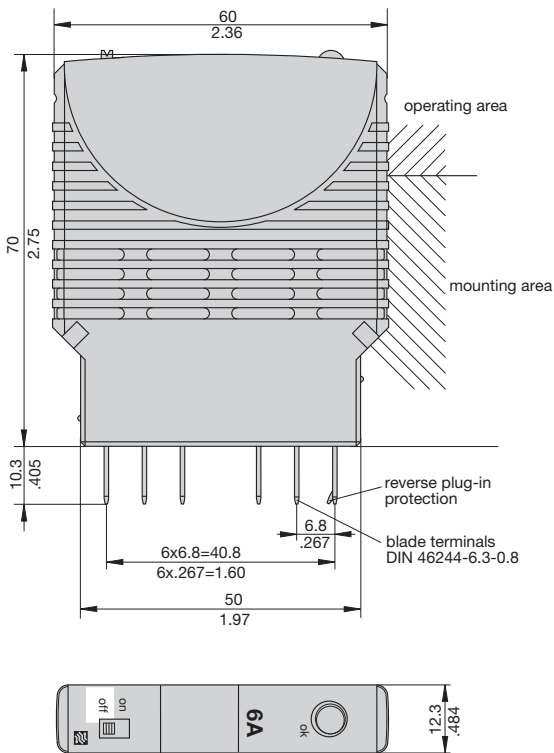

This is a metric design and millimeter dimensions take precedence ($\frac{mm}{inch}$)

Time/Current characteristic curve ($T_A = 25^\circ\text{C}$)

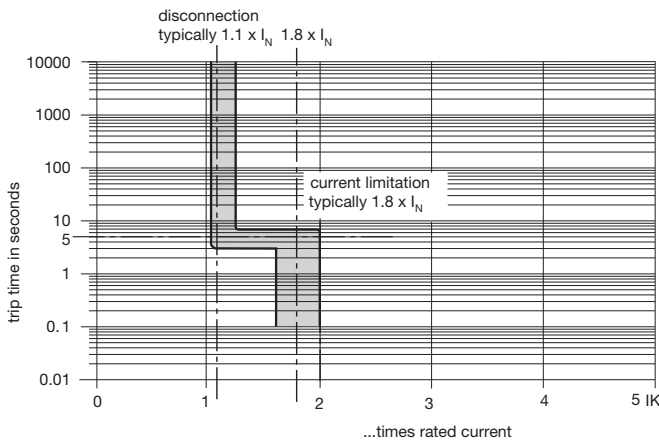

- The trip time is typically 3 s in the range between 1.1 and 1.8 x I_N^{*1} .
- Electronic current limitation occurs at typically 1.8 x I_N^{*1} which means that under all overload conditions (independent of the power supply and the resistance of the load circuit) the max. overload before disconnection will not exceed 1.8 x I_N^{*1} times the current rating. Trip time is between 100 ms (short circuit current I_K) and 3 sec (at overload with high line attenuation).
- Without this current limitation a considerably higher overload current would flow in the event of an overload or short circuit.

*1) current limitation typically 1.8 x I_N times rated current at $I_N = 0.5\text{ A} \dots 6\text{ A}$
 current limitation typically 1.5 x I_N times rated current at $I_N = 8\text{ A}$ or 10 A
 current limitation typically 1.3 x I_N times rated current at $I_N = 12\text{ A}$

Table 3: Reliable trip of ESX10

Reliable trip of ESX10 with different cable lengths and cross sections							
Resistivity of copper $\rho_0 = 0.0178$ (Ohm x mm^2) / m							
$U_S = \text{DC } 19.2\text{ V}$ (= 80 % v. 24 V)	voltage drop of ESX10 and tolerance of trip point (typically 1.1 x $I_N = 1.05 \dots 1.35$ x I_N) have been taken into account.						
ESX10-selected rating I_N (in A) →	3	6					
e. g. trip current $I_{ab} = 1.25$ x I_N (in A) →	3.75	7.5	→ ESX10 trips after 3 s				
R_{max} in Ohm = $(U_S / I_{ab}) - 0.050$ →	5.07	2.51					
The ESX10 reliably trips from 0 Ohm to max. circuitry resistance R_{max}							
Cable cross section A in mm^2 →	0.14	0.25	0.34	0.5	0.75	1	1.5
cable length L in meter (= single length)	cable resistance in Ohm = $(R_0 \times 2 \times L) / A$						
5	1.27	0.71	0.52	0.36	0.24	0.18	0.12
10	2.54	1.42	1.05	0.71	0.47	0.36	0.24
15	3.81	2.14	1.57	1.07	0.71	0.53	0.36
20	5.09	2.85	2.09	1.42	0.95	0.71	0.47
25	6.36	3.56	2.62	1.78	1.19	0.89	0.59
30	7.63	4.27	3.14	2.14	1.42	1.07	0.71
35	8.90	4.98	3.66	2.49	1.66	1.25	0.83
40	10.17	5.70	4.19	2.85	1.90	1.42	0.95
45	11.44	6.41	4.71	3.20	2.14	1.60	1.07
50	12.71	7.12	5.24	3.56	2.37	1.78	1.19
75	19.07	10.68	7.85	5.34	3.56	2.67	1.78
100	25.34	14.24	10.47	7.12	4.75	3.56	2.37
125	31.79	17.80	13.09	8.90	5.93	4.45	2.97
150	38.14	21.36	15.71	10.68	7.12	5.34	3.56
175	44.50	24.92	18.32	12.46	8.31	6.23	4.15
200	50.86	28.48	20.94	14.24	9.49	7.12	4.75
225	57.21	32.04	23.56	16.02	10.68	8.01	5.34
250	63.57	35.60	26.18	17.80	11.87	8.90	5.93
Example 1:	max. length at 1.5 mm^2 and 3 A → 214 m						
Example 2:	max. length at 1.5 mm^2 and 6 A → 106 m						
Example 3:	mixed wiring: R1 = 40 m in 1.5 mm^2 and R2 = 5 m in 0.25 mm^2 : (Control cabinet – sensor/actuator level) R1 = 0.95 Ohm, R2 = 0.71 Ohm Total (R1 + R2) = 1.66 Ohm						

Table 2: ESX10 - product version

version	signal input		signal output		
			signal output F		status output SF
ESX10 -...	control input ON/OFF +24 V Control IN+	reset input +24 V RE	group signal N/O	group signal change-over	status OUT +24 V = OK
-100					
-103				X	
-104					X
-115	X		X		
-124		X			X
-125		X	X		

ESX10 Signal inputs / outputs (wiring diagram)

ESX10 signal inputs / outputs (wiring diagrams)

Signal contacts are shown in the OFF or fault condition.

ESX10-100
without signal input/output

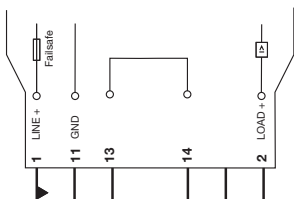

ESX10-103
without signal input
with signal output F (group signal, change-over)

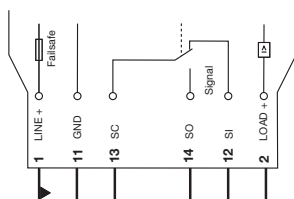

operating condition: SC/SO closed, SC-SI open
fault condition: SC/SO open, SC-SI closed

ESX10-104
without signal input
with status output SF (+24 V = load output ON)

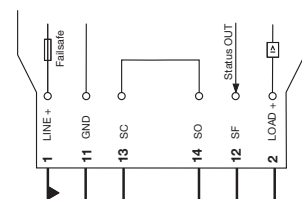

operating condition: SF +24 V = OK
fault condition: SF 0V

ESX10-115-...
with control input IN+ (+DC 24 V)
with signal output F (group signal, N/O)

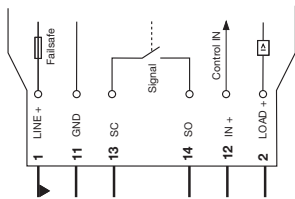

operating condition: SC-SO closed
fault condition: SC-SO open

ESX10-124-...
with reset input RE (+DC 24 V↓)
with status output SF (+24V = load output ON)

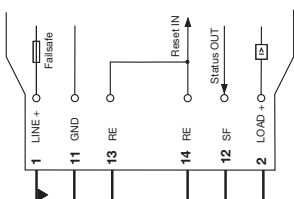

operating condition: SF +24V = OK
fault condition: SF 0V

ESX10-125-...
with reset input RE (+DC 24 V↓)
with signal output F (group signal, N/O)

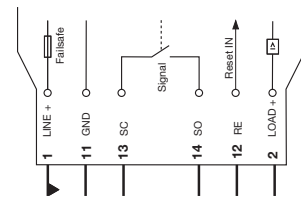

operating condition: SC-SO closed
fault condition: SC-SO open

This is a metric design and millimeter dimensions take precedence ($\frac{mm}{inch}$)

All dimensions without tolerances are for reference only. In the interest of improved design, performance and cost effectiveness the right to make changes in these specifications without notice is reserved. Product markings may not be exactly as the ordering codes. Errors and omissions excepted.

Accessories for ESX10

Description

Module 17plus is a power distribution system for use with electronic circuit protectors ESX10.

Each module accommodates two protectors with an individual housing width of only 12.5 mm and fits onto all industry standard mounting rails.

The two-way modules can be interconnected to provide as many ways as required with a terminal block fitted at each end for connection of signalling circuits. A distribution busbar can be fitted on the supply side of the modules (positive pole) though each pole of multipole circuit breakers must be individually connected.

Electrical connections are by means of spring-loaded terminals. The reference potential for the ESX10 (GND pin 11) is also looped through and connected to the terminal blocks at the sides.

The integral status output SF of the ESX10-104/-124 can be tapped at terminal 12 of the relevant channel (single signalisation). The reset input RE may be connected via terminal 13 or 14 (ESX10-124) or terminal 12 (ESX10-125). The integral control input IN+ of ESX10-115 is connected via terminal 12.

Depending on the version a potential-free signal contact is available (ESX10-103/-104/-115/-125).

Ordering information

17PLUS-Q02-00	Module 17plus, centre piece, two-way
17PLUS-QA0-LR	one each left- and right-side terminal block for supply feed from the side by means of screw terminal, connection of signalisation etc.

Pin configuration, fitted with ESX10-124 (Example)

ESX10-124 Modul 17 plus		
LINE (+)	(1)	operating voltage PLUS, DC 24 V
GND	(11)	operating voltage MINUS
RE	(13)	reset input RE
RE	(14)	reset input RE
SF	(12)	status output SF
LOAD (+)	(2)	protected load output

Approvals

Authority	Voltage ratings	Current ratings
UL 60950	AC 250 V; DC 80 V	50 A

All dimensions without tolerances are for reference only. In the interest of improved design, performance and cost effectiveness the right to make changes in these specifications without notice is reserved. Product markings may not be exactly as the ordering codes. Errors and omissions excepted.

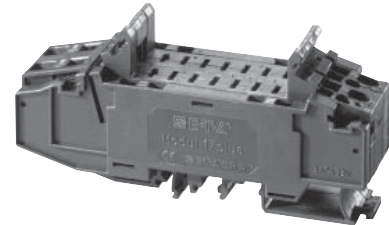

17plus

Technical data

Connection Spring-loaded terminals for solid conductors and stranded cables with and without wire end ferrules. Please use appropriate screw driver size (SD) for removing the spring loaded terminals.

cable	cross section of connecting cable	screw driver	stripped length
Line feed (1)	1.5-10 mm ²	3 (1.0 x 5.5)	12 mm
Load output (2)	0.25-4 mm ²	1 (0.6 x 3.5)	12 mm
Signalisation terminals (11, 13, 14)	0.25-2.5 mm ²	1 (0.6 x 3.5)	10 mm
Signalisation terminal (12)	0.25-1.5 mm ²	0 (0.4 x 2.5)	9 mm

Voltage rating (without ESX10) AC 250 V; 3 AC 433 V; DC 65 V

Current rating (without ESX10)

LINE feed (1)	50 A
LOAD output (2)	25 A
Reference potential GND (11)	10 A
single signal (12)	1 A (with ESX10: 0.5 A)
Group signal / (13-14)	1 A (with ESX10: 0.5 A)

Internal resistance values (without ESX10)

LINE-LOAD (1-2)	≤ 5 mΩ
Group signal (13-14) per module	≤ 8 mΩ per pole +5 mΩ for each additional module

Vibration 5 g (57-500 Hz) ± 0.38 mm (10-57 Hz), to IEC 60068-2-6, test Fc, 10 frequency cycles/axis

Shock 25 g (11 ms) to IEC 60068-2-27, test Ea 11 ms half sine

Corrosion 96 hours at 5 % salt mist, to IEC 60068-2-11, test Ka

Humidity 240 hours at 95 % RH to IEC 60068-2-78, test Cab

Dielectric strength of Module 17plus (without ESX10)
 between main circuits (without busbar): 1,500 V
 main circuit to auxiliary circuit: 1,500 V
 between auxiliary circuits: 1,500 V

Mass: Module 17plus (centre piece) approx. 85 g
terminal blocks (pair) approx. 30 g

Dimensions

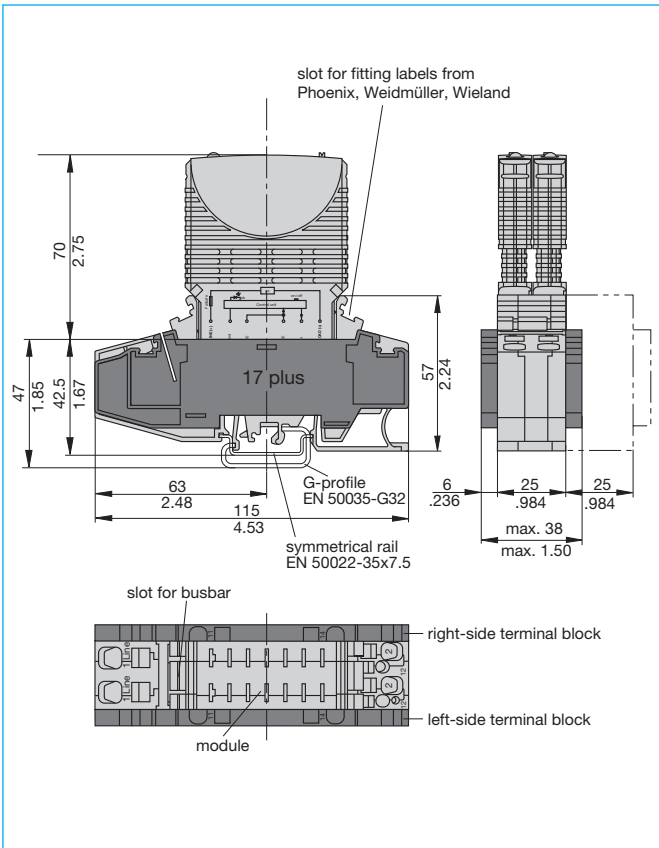

This is a metric design and millimeter dimensions take precedence ($\frac{mm}{inch}$)

Installation example

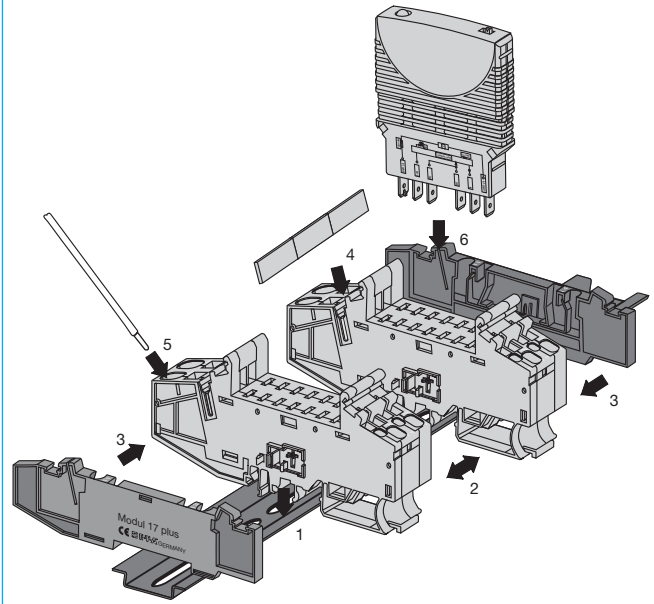

Installation:

- 1 Clip modules onto DIN rails.
- 2 Push modules together (side-by-side).
- 3 Snap on right-side and left-side terminal blocks.
- 4 Cut busbar to required length and fit on supply side of the modules.
- 5 Connect line feed with spring-loaded terminals.
- 6 Plug in ESX10.

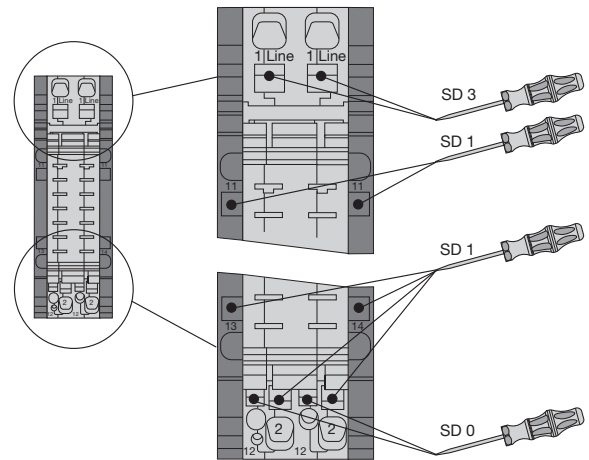

Connection and disconnection of cables with screw driver

Connection diagram for ESX10-...

Module 17plus with ESX10-100

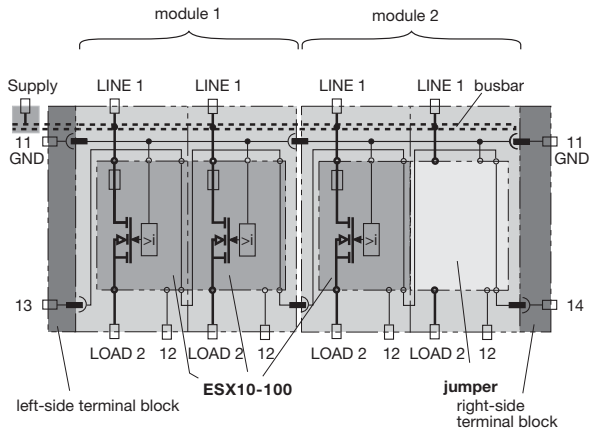

11 GND
13, 14 looped through

Module 17plus with ESX10-103

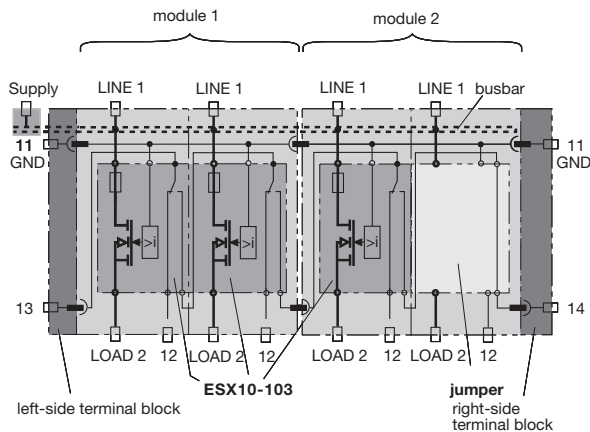

11 GND
12, 13, 14 terminal group signalling (change-over)
(13-12 N/C, 13-14 N/O)

Module 17plus with ESX10-104

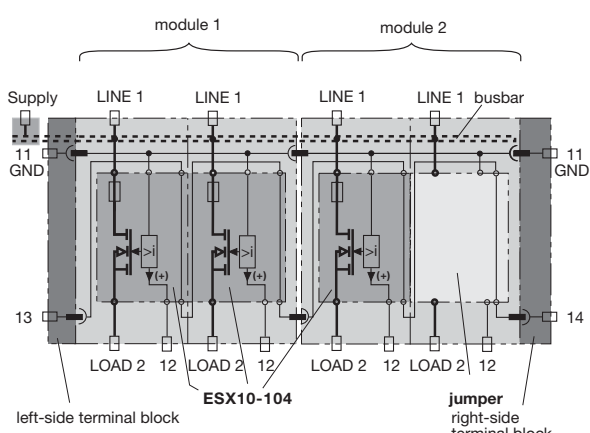

11 GND
12 status indication SF +24V=OK
13, 14 looped through

Module 17plus with ESX10-115

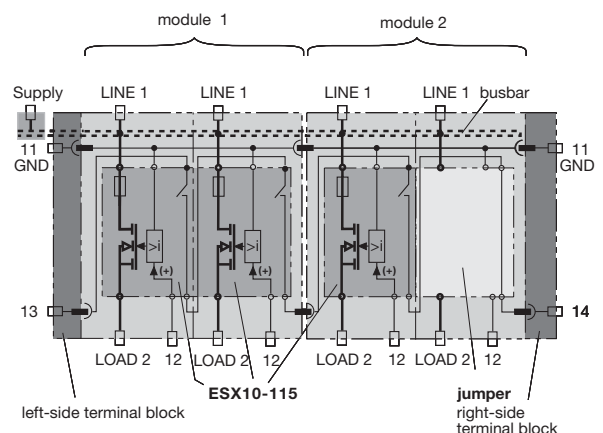

11 GND
12 terminal control signal ON (+24V DC)
13, 14 terminal group signalling (N/O)

Module 17plus with ESX10-124

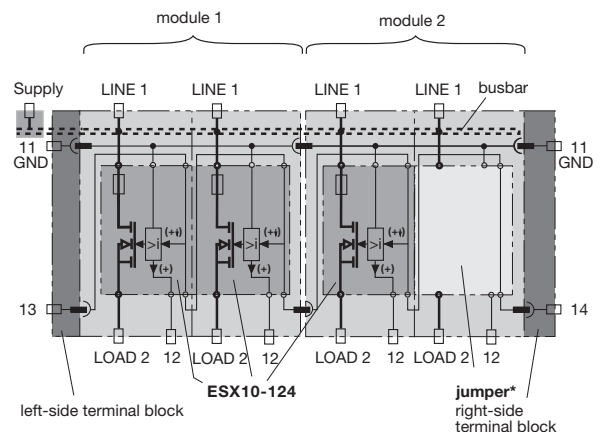

11 GND
12 status indication SF +24V=OK
13, 14 reset input RE (group reset), +24V falling edge
*Caution: unused slots have to be fitted with jumpers

Module 17plus with ESX10-125

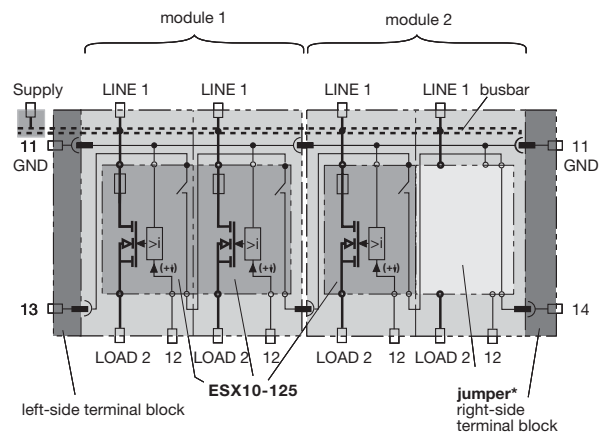

11 GND
12 reset input RE (single reset), +24V falling edge
13, 14 terminal group signalling (N/O)
*Caution: unused slots have to be fitted with jumpers

Accessories for ESX10

Busbar 32 A
X 222 005 01 blue insulation, 500 mm/19.68 in.
X 222 005 02 red insulation, 500 mm/19.68 in.
X 222 005 03 grey insulation, 500 mm/19.68 in.
 "up to 32 A continuous load"

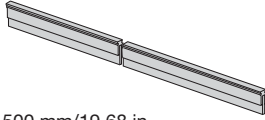

Busbar 50 A
Y 307 016 01 non-insulated, 500 mm/19.68 in.
 "up to 50 A continuous load; plugged in completely, protected against brush contact"

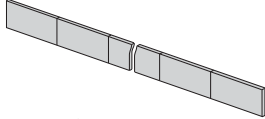

Busbar 50 A
Y 307 016 11 non-insulated, 500 mm/19.68 in.
 "up to 50 A continuous load"

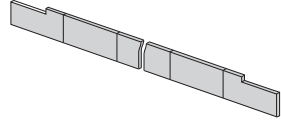

End bracket
X 222 004 01
 Width 10 mm

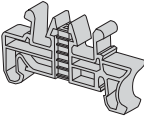

Screw terminal for busbar
X 211 156 01 non insulated



Jumper
SB-S11-P1-01-1-1A

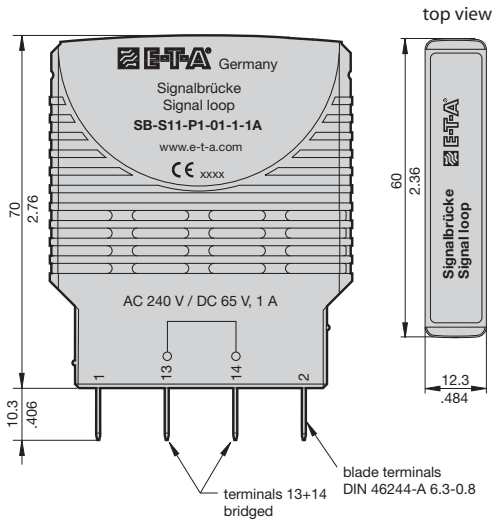

Retaining clip for electronic circuit breaker typ ESX10
Y 308 729 01

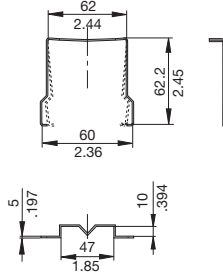

Labels
 marking area 6 x 10 mm
 (packing unit 10 pcs = 1 strip)
 part. no. **Y 307 942 61**

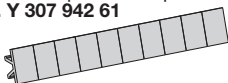

Accessories for ESX10

Retaining clip Y 307 754 01

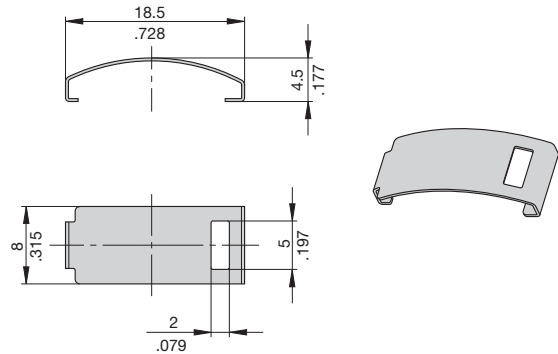

Mounting of retaining clip

ESX10 with retaining clip **Y 307 754 01**
 for power distribution system module 17plus

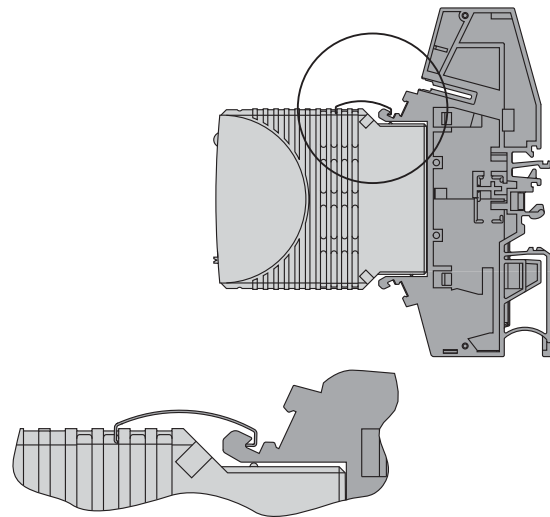

Removal of retaining clip Y 307 754 01

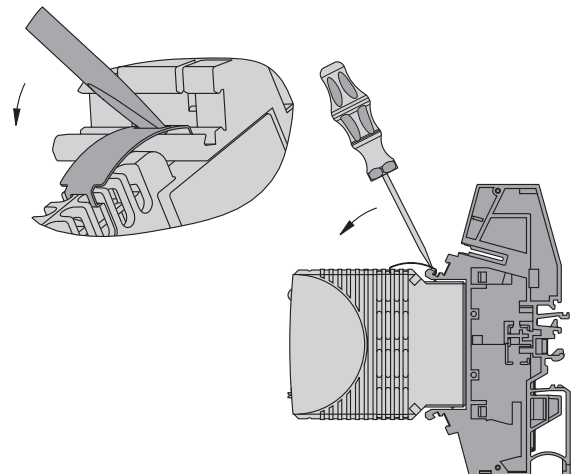

Accessories for ESX10

Single mounting sockets

(up to 16 A max. load)

17-P10-Si

17-P70-Si

(retaining clip Y 308 792 01)

polarized blade terminal
DIN 46244-A6.3-0.8 (QC .250)

(with adapter)

17-P10-Si-20025

17-P70-Si-20025

blade terminal DIN 46244 part 2
C profile (2x A2.8-0.8) (QC 2x.110)

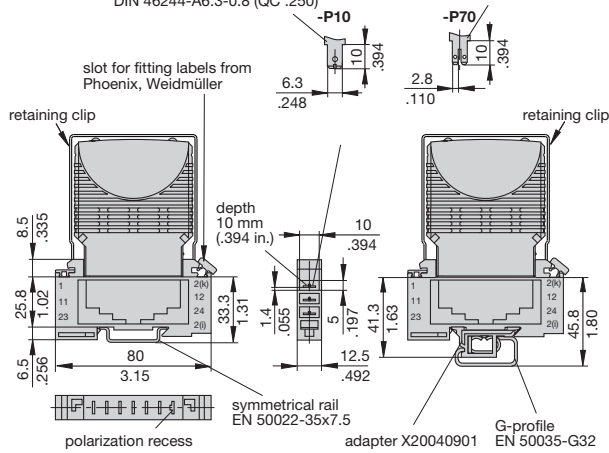

Busbar (10-way) (supplied as a complete package) for type 17 socket

(for max. 100 A continuous load,
more positions available on request)

X 211 157 01 with terminal

X 211 157 02 without terminal

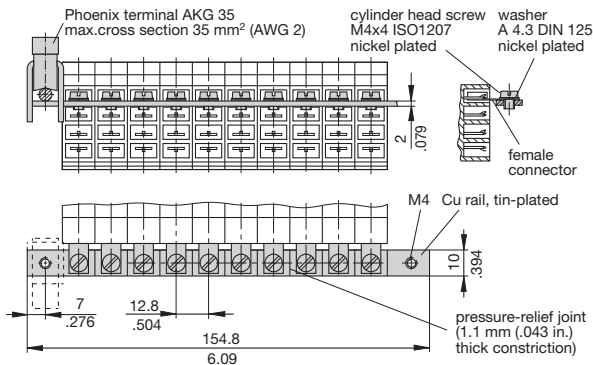

Insulating sleeving for busbar (10-way) Y 303 824 01

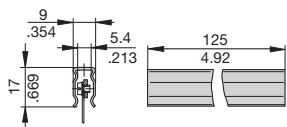

2-way mounting socket

23-P10-Si

(retaining clip Y 300 581 03 available on request)

6-way mounting socket

63-P10-Si

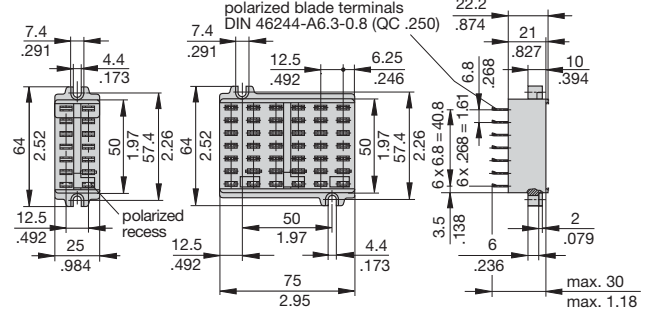

Connector bus links -P10

X 210 588 01/ 1.5 mm², (AWG 16), brown (up to 13 A max. load)

X 210 588 02/ 2.5 mm², (AWG 14), black (up to 20 A max. load)

X 210 588 03/ 2.5 mm², (AWG 14), red (up to 20 A max. load)

X 210 588 04/ 2.5 mm², (AWG 14), blau (up to 20 A max. load)

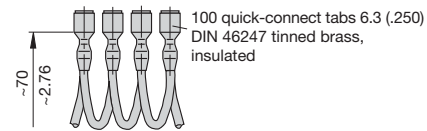

Pin selection, fitted with ESX10-124 (Example)

ESX10-124 17-P10-Si

LINE (+)	[2(k)]
GND	[12]
RE	[24]
	[2(i)]
RE	[23]
SF	[11]
LOAD (+)	[1]

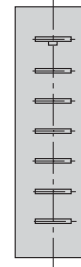

This is a metric design and millimeter dimensions take precedence ($\frac{\text{mm}}{\text{inch}}$)

Table 4: ESX10-... - Pin assignment 17-P10-Si

17-P10-Si	ESX10-					
Pins	-100	-103	-104	-115	-124	-125
[2(k)]	LINE (+) DC +24 V	LINE (+) DC +24 V	LINE (+) DC +24 V	LINE (+) DC +24 V	LINE (+) DC +24 V	LINE (+) DC +24 V
[12]	GND	GND	GND	GND	GND	GND
[24]		group SF changeover terminal		group SF N/O	reset IN+ +24 V ↓	group SF N/O
[2(i)]	not assigned	not assigned	not assigned	not assigned	not assigned	not assigned
[23]		group SF changeover N/O		group SF N/O	reset IN+ +24 V ↓	group SF N/O
[11]		group SF changeover N/C	status OUT +24 V = OK	control signal IN+ +24 V = ON	status OUT +24 V = OK	reset IN+ +24 V ↓
[1]	LOAD (+)	LOAD (+)	LOAD (+)	LOAD (+)	LOAD (+)	LOAD (+)

