

Flow Meter FC01-CA

User handbook



Flow Meter FC01-CA

Please follow these installation and adjustment instructions carefully.
Failure to comply with these instructions or misuse of this equipment will void your warranty coverage.

The instructions cover software version 2.50.



Equipment installation, connection and adjustment by qualified personnel only!

Table of contents

1	Description	1
1.1	Measuring procedures	1
1.1.1	Calorimetric measuring procedure	1
1.1.2	Physical principles of gas measurement	2
1.1.3	Standard and operating volume flow	2
1.1.4	Measurements in compressed-air systems	3
1.1.4.1	Consumption measurements	3
1.1.4.2	Leakage measurements	3
1.2	System description	4
1.2.1	User interfaces	5
2	Installation	7
2.1	Installation of calorimetric monitoring heads	7
2.1.1	Selection of material	7
	Stainless steel 1.4571/AISI 316 Ti	7
	Nickel-based alloy (Hastelloy 2.4610)	7
2.1.2	Mechanical installation	8
2.1.2.1	Thread-mounted monitoring head CST-11	8
2.1.2.2	Insertion head CSP for sensor adapter TP-...	8
2.1.2.2.1	Sensor adapter TP-...	9
2.1.2.2.2	Ball valve	10
2.1.2.3	Push-in monitoring head (CSF-11AM1)	11
2.1.3	Mounting instructions for monitoring head CSP-.. with sensor adapter TP-..	13
2.1.4	Mounting instructions for push-in monitoring head CSF-11...	13
2.1.5	Point of installation and steadying zones	15
2.1.6	Condensate deposits	16
2.1.7	Electrical connection	16
2.2	Installation of electronic control unit FC01-CA	17
2.2.1	Mechanical installation	17
2.2.1.1	Rail-mounted version FC01-CA-U1...	17
2.2.1.2	Surface mounted housing FC01-CA-FH-U1...	18
2.2.1.3	Front panel mounted version FC01-CA-ST-U1...	19
2.2.2	Electrical connection	20
2.2.2.1	Circuit diagram FC01-CA 24 V (relay outputs)	23
2.2.2.2	Circuit diagram FC01-CA 24 V (transistor outputs)	24
2.2.2.3	Electrical connection - frequency output (version FC01-CA-U1T4)	25

3 Operating system	27
Keypads (M) MODE, (▲) UP and (▼) DOWN	27
Menu paging	28
Calling a menu option	28
Entry of numerals	28
Transfer of entries	28
Deleting data	28
4 Operation and main menu	29
4.1 Switch-on performance	29
4.2 Measuring cycle	29
4.2.1 Operating data	30
4.2.1.1 Measured value(s)	30
4.2.1.2 Peak values (PEAK VALUE MIN / PEAK VALUE MAX.)	32
4.2.1.3 Low flow suppression (ZERO SUPP.)	32
4.2.1.4 Last error (LAST ERROR)	32
4.2.1.5 Main menu	33
5 Configuration (CONFIGURATION)	34
5.1 Selection of monitoring head (SENSOR SELECT)	34
5.2 Pressure range (PRESS. RANGE)	35
5.3 Volume flow measuring mode (OPERAT. MODE)	35
5.4 Gas selection (GAS SELECT)	36
5.5 Limit switch combinations (LIMIT SWITCHES)	36
5.6 Flow rate unit (FLOW UNIT)	37
5.7 Medium temperature unit (TEMP. UNIT)	37
5.8 Display (DISPLAY SELECT)	38
5.9 Bar graph (BARGRAPH)	39
5.10 Frequency output (FREQUENCY OUTPUT)	40
5.11 Analogue output - flow rate (ANA OUT FLOW)	41
5.12 Analogue output - medium temperature (ANA OUT TEMP.)	41
5.13 Quitting the configuration menu	41
5.14 Configuration menu	43
5.15 Configuration submenus	44

6	Parameter selection (PARAMETERS)	47
6.1	Measuring time (MEAS. TIME)	47
6.2	Limit switch 1 ON/OFF value (LS1 ON, LS1 OFF)	47
6.3	Limit switch 2 ON/OFF value (LS2 ON, LS2 OFF)	48
6.4	Scaling factor (FLOWSCALE)	48
6.5	Quitting the parameter selection menu	49
6.6	Parameter selection menu	50
7	Low flow suppression	51
7.1	Low flow suppression	51
7.2	Zero adjustment	51
8	Errors	52
8.1	Test and diagnosis	52
8.1.1	Priority group I	52
8.1.2	Priority group II	52
8.1.3	Priority group III	52
8.2	Potential errors	53
9	Technical data	55
9.1	Ambient conditions	55
9.2	Electrical characteristics	55
9.2.1	Power supply	55
9.2.1.1	DC voltage supply	55
9.3	Analogue outputs	56
9.3.1	Voltage output V1 - 5 V FS	57
9.3.2	Voltage output V2 - 10 V FS	57
9.3.3	Current output C1 - 20 mA FS	57
9.4	Signal outputs	58
9.4.1	Relay outputs R2	58
9.4.2	Transistor outputs (DC)	59
9.5	Metrological data	60
9.5.1	Mass flow measurement	60
9.5.1.1	Monitoring head CSP-.. with sensor adapter TP-..	60
9.5.1.2	Monitoring head CSF-..	61
9.5.2	Temperature measurement	62
9.5.3	Electronic control unit	62
9.6	Sensor interface	63
9.6.1	Electrical data of the terminal for calorimetric monitoring head	63

10 Accessories 64

Index

Appendix

- 1 Performance of the digital and analogue outputs during operating and error modes
- 2 Menu structure of the FC01-CA (operator dialogue)

1 Description

Flow Meter FC01-CA is suitable for compressed-air and other gas flow measurements under various pressure conditions. It operates on the calorimetric principle and is to be used together with monitoring heads CS_...

These quantities are made available to the user as analogue electrical signals, physically isolated, as **current** or **voltage output** and may be monitored by means of a **limit monitor**.

As **relay outputs** or **transistor outputs** the digital signals enable the user to integrate the FC01-CA into a control and monitoring system.

The transistor outputs enable the user to additionally process **fault**, **status** and **volume pulse indications** in the control system.

1.1 Measuring procedure

1.1.1 Calorimetric measuring procedure

The calorimetric measuring procedure is based on the physics of heat dissipation, i.e. a body with a temperature higher than its surroundings supplies a medium flowing past that body with energy in the form of heat. The amount energy supplied is a function of temperature difference \varnothing and mass flow.

Flow Meter FC01-CA operates on the CTD (Constant-Temperature-Difference) method:

The temperature difference \varnothing between the two sensors is kept constant and the mass flow is determined by measuring the calorific power.

Fig. 1 is a schematic diagram of a CTD method based sensor. Two temperature-sensitive resistors (sensor elements RS and RM) are immersed in the medium. Sensor RM assumes the temperature of the medium ϑ_M whilst heater resistor RH heats element RS to temperature ϑ_S . As a function of the medium, the temperature differential $\varnothing = \vartheta_S - \vartheta_M$ is preselected as a reference variable by the CTD control with characteristics and is kept constant. The required calorific power is a function of mass flow so that the control variable **y** of the control can be used for evaluation.

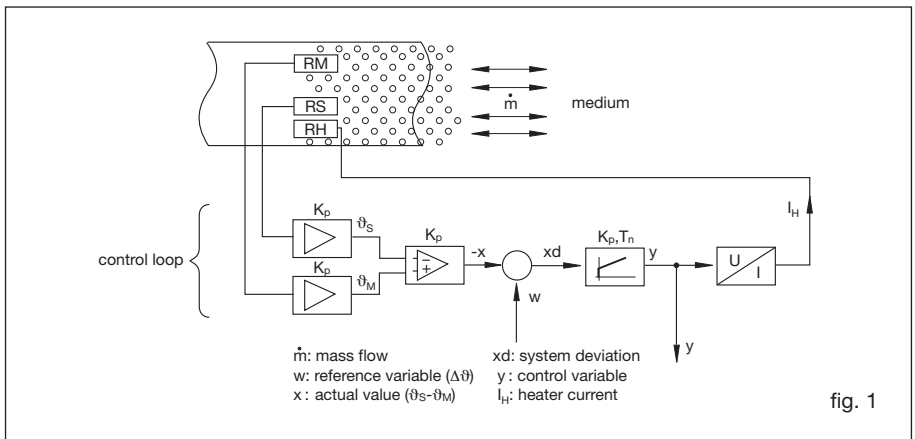

Major benefits of this method are:

- Fast response, particularly to sudden flow standstill.
- Medium temperature measurement, providing optimum temperature compensation.
- Increased safety because the sensor cannot be overheated during flow standstill.

The flow rate is determined by mass flow.

1.1.2 Physical principles of gas measurement

With the exception of Coriolis meters and calorimetric flow meters, flow meters used for gas measurement are pure volume flow meters that require density to determine mass flow Q from the volume flow measured:

$$Q = V \times \rho$$

Coriolis meters are used for higher mass flow quantities and higher densities only, where density is directly proportional to pressure and inversely proportional to temperature (related to absolute Kelvin scale).

The quantity required in general practice is mass flow as it indicates the exact gas quantity, whereas volume flow only defines the volume the gas has adopted during the measurement procedure.

1.1.3 Standard and operating volume flow

Standard volume flow

The calorimetric measuring procedure measures the existing standard volume flow or mass flow without requiring additional pressure and/or temperature measurements. Like velocity changes, pressure fluctuations cause fluctuations in standard volume flow which are indicated as such. The standard volume flow indicated relates to 1,013 mbar/ 14.89 PSI and a temperature of 0 °C.

Operating volume flow

The standard volume flow value is converted into operating volume flow by means of the “ideal gas equation”:

$$\frac{P \times V}{T} = \text{constant}$$

with P being pressure, V the volume and T the temperature (related to the absolute Kelvin scale). The pressure to be set on the electronic control unit FC01-CA and the current temperature measured are taken into account and used as a basis. Calculating operating volume flow is only reasonable when pressure is known and constant.

The assigned velocity rates (averaged on the pipe section) are converted from standard conditions to operating conditions the same way as volume flow.

1.1.4 Measurements in compressed-air systems

The easy-to-fit modular insertion system allows the FC01-CA with insertion head CSP-.. to be inserted in 6 different sensor adapters for diameters 1/2", 3/4", 1", 1 1/4", 1 1/2" and 2". This enables to systematically monitor the entire compressed-air system for leakages by providing the appropriate number of sensor adapters and only a few measuring systems. After elimination of the leakages the measuring system can be used for consumption measurements on other measuring locations, e.g. before main loads or in larger pipes of the compressed-air system. The measuring range covering approx. 0 ... 50 Nm³/h to approx. 0 ... 480 Nm³/h allows the measurement of nearly all common flow rates as a function of pipe diameter.

Measurements in larger pipe diameters are possible by using the push-in monitoring head CSF-11AM1.

1.1.4.1 Consumption measurements

The FC01-CA with CS_- monitoring head is suitable for compressed air and other gases. Its electronic control unit comprises two freely scalable linearised analogue outputs, i.e. one for temperature, the other for mass flow, standard flow or operating volume flow. A pulse output and totalizer for consumption measurements are other added features. It also provides limit value monitoring of flow and temperature, ensuring reliable operation of the load.

1.1.4.2 Leakage measurements

When monitoring compressed-air flow at some selected points during a production-free period, you will realise that even in carefully maintained compressed-air systems there is still compressed air consumed. Reliably detecting even the smallest of such leakage losses can be facilitated by means of the adjustable zero suppression of the FC01-CA. If the system is permanently monitored for leakage flow, leakages caused by valves left open etc. and new leakage points can easily be detected.

The FC01-CA also allows the detection of leakages on duty by comparing two equal loads with each other. The difference measured can be directly assigned to the leakage flow.

Note:

- Please see the applicable drawing for mounting instructions and dimensions, if necessary.

1.2 System description

The system comprises the following hardware functional modules:

- | | | |
|----------------------------|--|--|
| 1 Input voltage | DC supply (terminal XV) | |
| 2 User interfaces: | 2.1 signal outputs | 2-way or 4-way signal outputs (terminal XAH) |
| | 2.2 analogue output | 1 and 2 (terminal XAO) |
| 3 Keyboard and display: | keypads | |
| | liquid crystal display | |
| 4 Sensor interface: | calorimetric monitoring head type CS _x (terminal XSK) | |
| 5 Micro controller system: | signal processing and monitoring | |

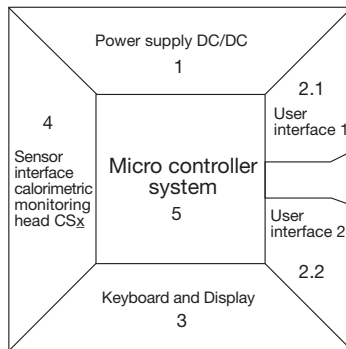

- | | | |
|-----------------------|--|---|
| 1 Input voltage: | DC 19 ... 32 V | |
| 2.1 User interface 1: | relay outputs: | 2 limit values |
| | transistor outputs: | 2 limit values +
1 error indication +
1 busy signal or
frequency output
(software selected) |
| 2.2 User interface 2: | analogue outputs
current or voltage | |
| 3 Keyboard/Display: | keypads
LC display
2 x 16 digits | |
| 4 Sensor interface: | calorimetric monitoring head type CS _x | |
| 5 Controller system: | signal processing
I/O - controlling
monitoring
parameter memory | |

fig. 2

The power supply is physically isolated between power supply input and system power supply output. This also applies to the analogue outputs which are physically isolated from each other as well as from the other electronics and the signal outputs. The signal output channels are also separate and electrically isolated from the central electronic unit.

There is no electrical isolation between monitoring head and central electronic unit.

Connection of the monitoring heads is by means of precut cable links.

Cables and user interface connections are shown in para. 2.2.2 and circuit diagram 2.2.2.1/ 2.2.2.2.

System configuration and parameter setting are by means of the keyboard if **default values** need to be changed. (paras. 5 and 6)

This mainly applies to monitoring head selection, signal outputs (switch point setting) and analogue outputs (zero point setting and scaling).

1.2.1 User interfaces

Signal outputs:

(optional)

1. **R2** - Relays outputs (2 limit values)

Two-channel physical isolation, relay change over contact

The channels may be assigned in menu "CONFIGURATION", either individually or in pairs, to the physical quantities of temperature or flow. The switch on and off values can be set as desired in menu "PARAMETERS" (yet within the measuring range) for each contact.

Please see para. 9.4.1 for electrical connection.

2. Transistor outputs (2 setpoints + 2 status outputs or 2 setpoints + 1 status output + 1 frequency output)

Four-channel physical isolation, transistor output - collector/emitter freely connectable

Channel 1: common error signal

Channel 2: busy signal or frequency output

Channels 3 and 4: Both channels may be assigned individually or in pairs to the physical quantities of temperature or flow. The switch on or off values of each transistor output can be set as desired.

Please see para. 9.4.2 for electrical connection.

Analogue outputs:

Two-channel physical isolation, current or voltage output

Please see the ordering number to find out whether it is a current or voltage output.

Output quantities: 0/1 - 5 V FS (option V1)

0/2 - 10 V FS (option V2)

0/4 - 20 mA FS (option C1)

These FS (full scale) output quantities apply to both channels as standard.

20% zero elevation and FS value can be programmed. (See para. 5.11)

Shield connections are ungrounded.



The shields of the signal cables should be applied on one side only.

Power supply:

DC 24 V supply

Internal switch mode power supply with physical isolation of the primary and secondary side.



Noise emission on the connection cable is limited by circuit design and filter.

A PTC resistor provides protection from overcurrent. The element automatically resets upon removal of the disturbance or after disconnection of the supply voltage of the FC01-CA for approx. 1 s (e.g. remove terminal XV).

Please see para. 9.2.1 for technical characteristics.

2 Installation

2.1 Installation of calorimetric monitoring heads

These are general directions for the application of calorimetric measuring heads which from application to application should be reviewed by the user in accordance with individual requirements.

2.1.1 Selection of material

Stainless steel 1.4571/AISI 316 Ti

The standard monitoring head material is stainless steel 1.4571/AISI 316 Ti, an austenitic, acid-resisting stainless steel that is commonly used throughout industry. Manufacturers claim it also withstands oxidizing organic and anorganic acids, and partly even reductive media.

The resistance of this stainless steel should however be verified by the user, particularly when it is used in medium mixtures that may from time to time be exchanged with cleansing agents. Its chemical resistance also depends on temperature, flow rate and concentration of the medium.

Stainless steels owe their resistance to rust mainly to their alloy combination with chromium, the formation of chromic oxide on the steel surface resulting in a passive state. Contamination, deposits on the surface, or foreign rust may however neutralize the passivity. Therefore care should be taken to keep the surfaces clean.

Stainless steel heads must not get in contact with steel parts other than stainless steel or with chemically dissimilar metals, as this would cause electrolytic corrosion.

Nickel-based alloy (Hastelloy 2.4610)

Hastelloy 2.6410 is a material with a chemical resistance generally exceeding that of stainless steel and copper-based alloys. They are particularly suitable for alkaline media (pH > 7). They should however be examined for suitability for each specific application using resistance tables and pragmatical values.

2.1.2 Mechanical installation

2.1.2.1 Thread-mounted monitoring head CST-11

Application: general industry and installation

Medium: gases

Styles: G1/2A

Materials of the area exposed to medium: stainless steel 1.4571 /AISI 316 Ti (standard)
nickel based alloy (Hastelloy C4 2.4610)

If installed in fittings or T pieces with appropriate internal thread the max. length of the connection piece should be 36 mm from the inner pipe wall.

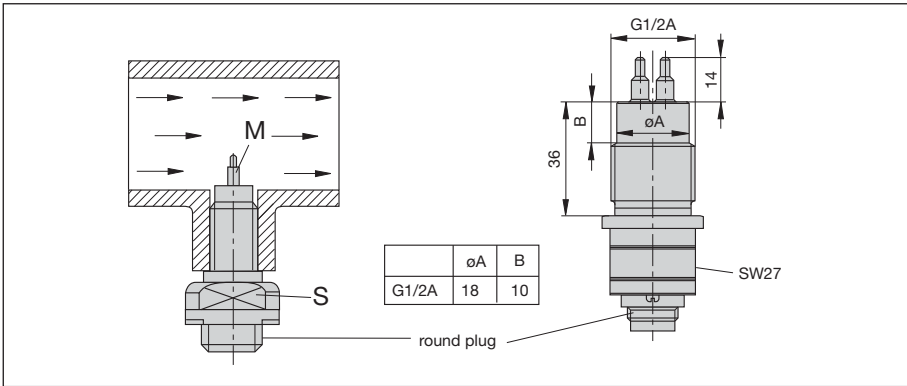

2.1.2.2 Insertion head CSP for sensor adapter TP-..

Application: general industry and installation

Style: insertion-type for sensor adapter TP-... and ball valve

Installation: sensor adapter TP-.. (fig. 4)
ball valve BV-.. (fig. 5)

Material of the area exposed to medium: stainless steel 1.4571/AISI 316 Ti, electropolished
O ring viton

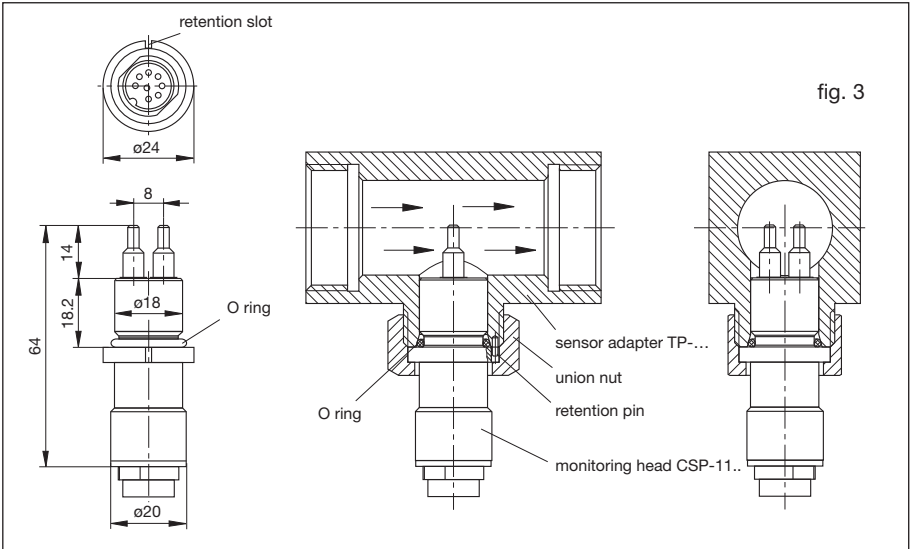

fig. 3

2.1.2.2.1 Sensor adapter TP-..

The sensor adapter TP-.. is available in 6 pipe diameters from 1/2" to 2".

Material of the area exposed to medium:

- brass or
- stainless steel 1.4571/AISI 316 Ti

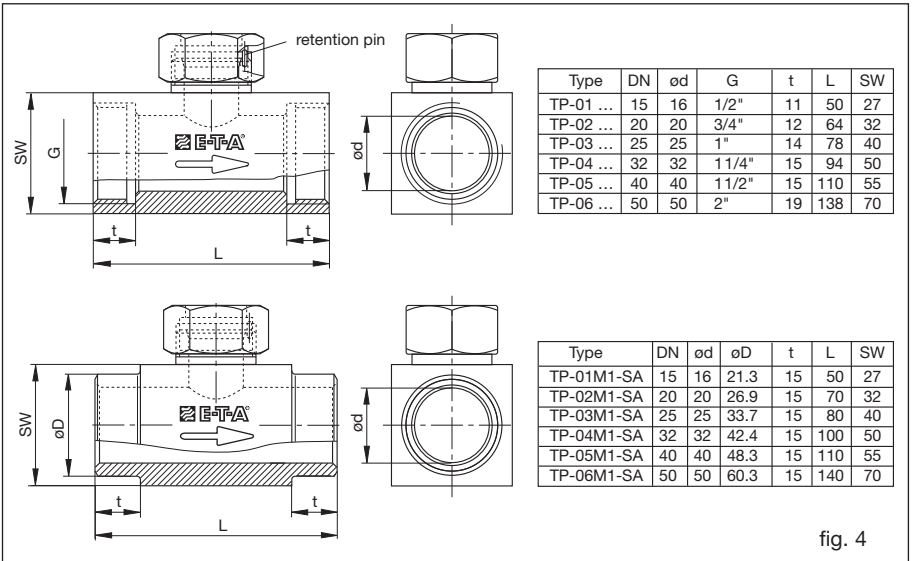

fig. 4

2.1.2.2.2 Ball valve

The ball valve is available in 4 nominal diameters from 1" to 2".

The ball valve ensures the sensors are fully immersed in the medium.

The monitoring head may also be replaced in pressurised pipe systems on duty.

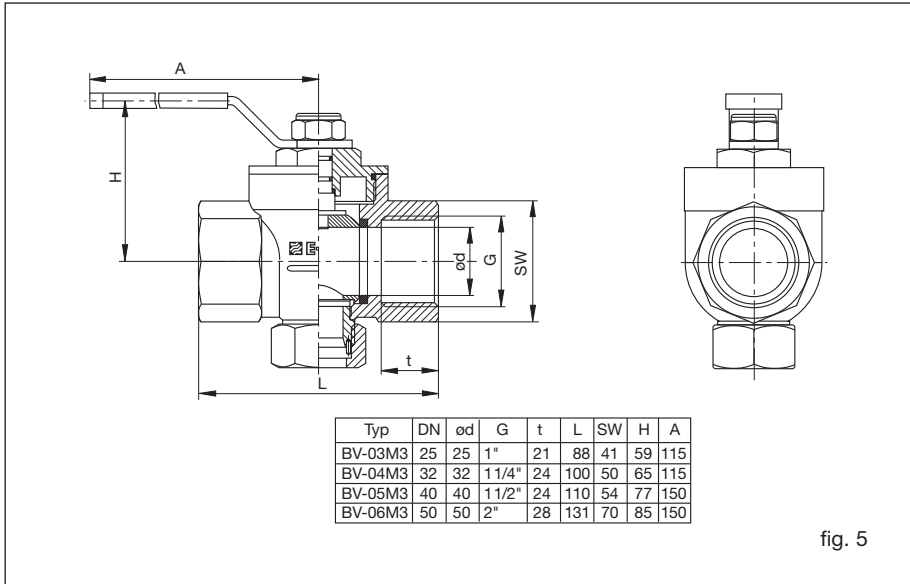

fig. 5

2.1.2.3 Push-in monitoring head (CSF-11 AM1)

Application: general industry and installation recommended for inner pipe dia. >60 mm

Style: push-in monitoring head

Material of the area exposed to medium: stainless steel 1.4571/AISI 316 Ti

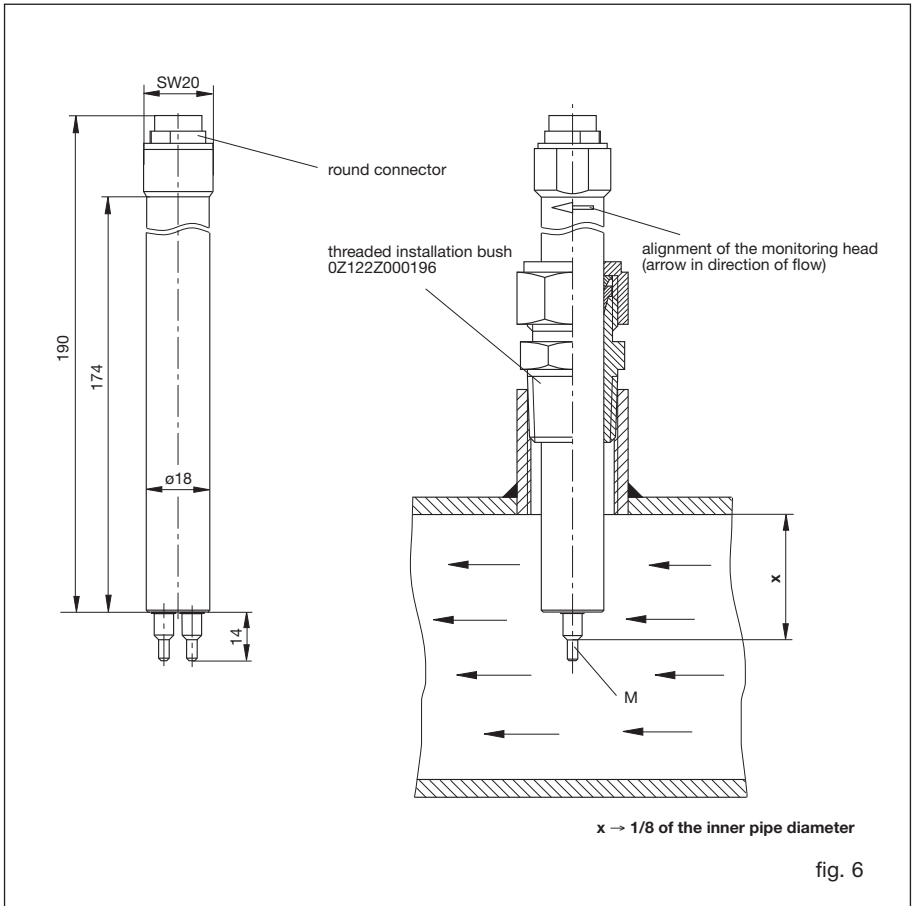

Standard velocity profiles:

(for pipe radius = 1 and for velocity averaged via total pipe cross section = 1)

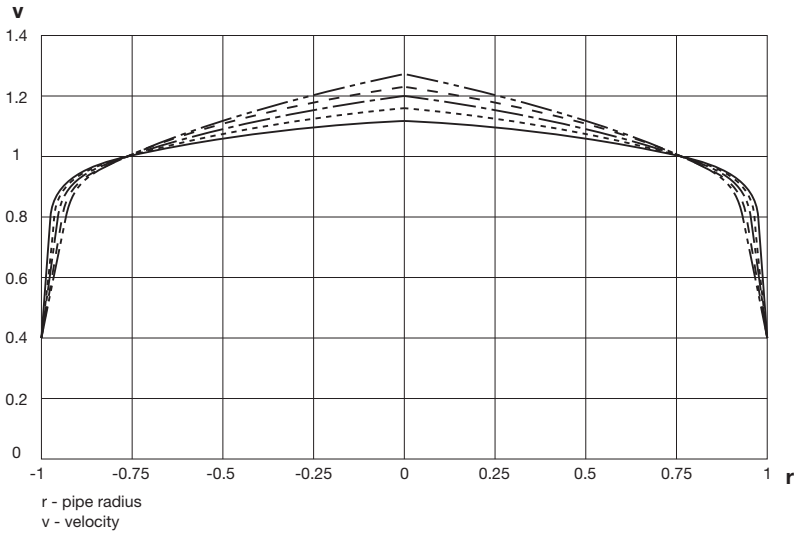

Velocity range at X = 1/8 dia.

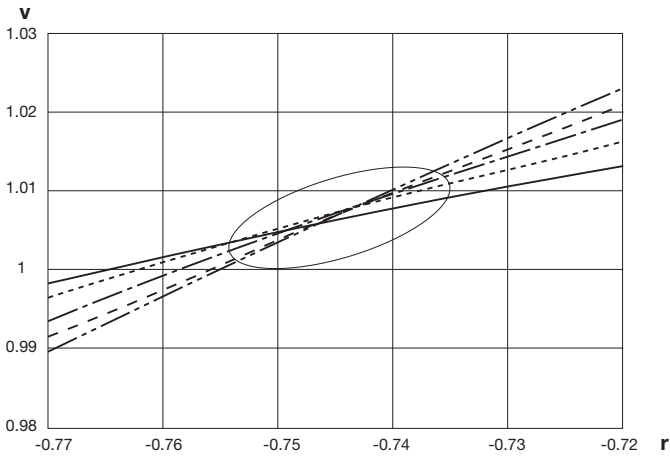

fig. 7

Max. accuracy is achieved with an insertion depth of $x = 1/8$ inner pipe dia. (fig. 7).

2.1.3 Mounting instructions for monitoring head CSP-.. with sensor adapter TP-..

Caution!



The monitoring head should only be installed or removed when the pipes are unpressurised. To ensure the safety label is clearly visible, it should be affixed on to or close to the measuring point.

- Insert the monitoring head with the O ring into the sensor adapter and tighten the union nut (observe correct retention). (See fig. 3)

The retention pin ensures correct alignment of the monitoring head after the union nut has been tightened.

Correct immersion depth of the monitoring head is ensured by the stop provided.

Sealing of the monitoring head in the sensor adapter is by means of the O ring provided (fig. 3).

- Screw the sensor adapter into the pipe, using hemp, teflon tape or sealing glue (thread sealing glue) for sealing.

2.1.4 Mounting instructions for push-on monitoring head CSF-..

Caution!



The two sensors (M) (fig. 6) should be screwed into the pipeline far enough to ensure that they are aligned side by side directly across the direction of flow. The sensors are correctly positioned when the wrench flats are aligned parallel with the pipeline.

The shoulder of the sensor (7 mm from the tip) must be at the position 1/8 from dia. i.

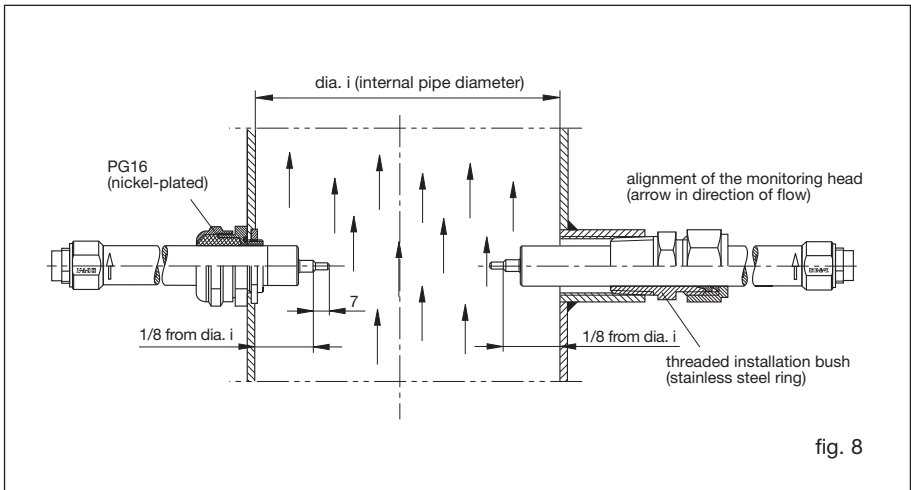

- Fit monitoring head with locking set as follows (fig. 9):
 - Fix first link of chain (1) into the clip (3) (tightening torque 10 Nm).
 - Put chain catch (2) into link and fasten with the tight chain.

Caution!



Check locking system with regard to strength!

The locking chain must be mounted as tightly as possible.

Locking set 01

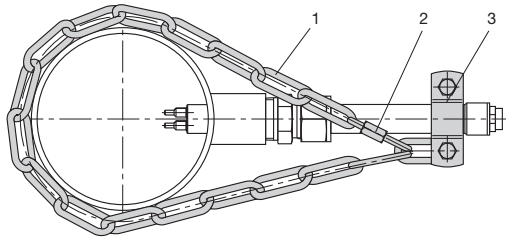

- 1 chain 4 x 32 DIN 5685 (approx. 1 m)
- 2 catch for chain NG 5
- 3 clip with screws and nuts DN15 to DIN 11850 (tightening torque 10 Nm)

fig. 9

2.1.5 Point of installation and steadying zones

The mounting attitude is unimportant. It is generally sufficient to have a distance of 10 pipe diameters (D) before the monitoring head if the velocity profile is only slightly disturbed. For much disturbed velocity profiles, above all for a superimposed swirl-flow, there should be a distance of 20 to 50 pipe diameters (D) before the monitoring head in order to eliminate high deviations in the values measured.

It is generally recommended to observe the following distances:

- distance before the monitoring head **15 ... 20 x D**
- distance after the monitoring head **5 x D**

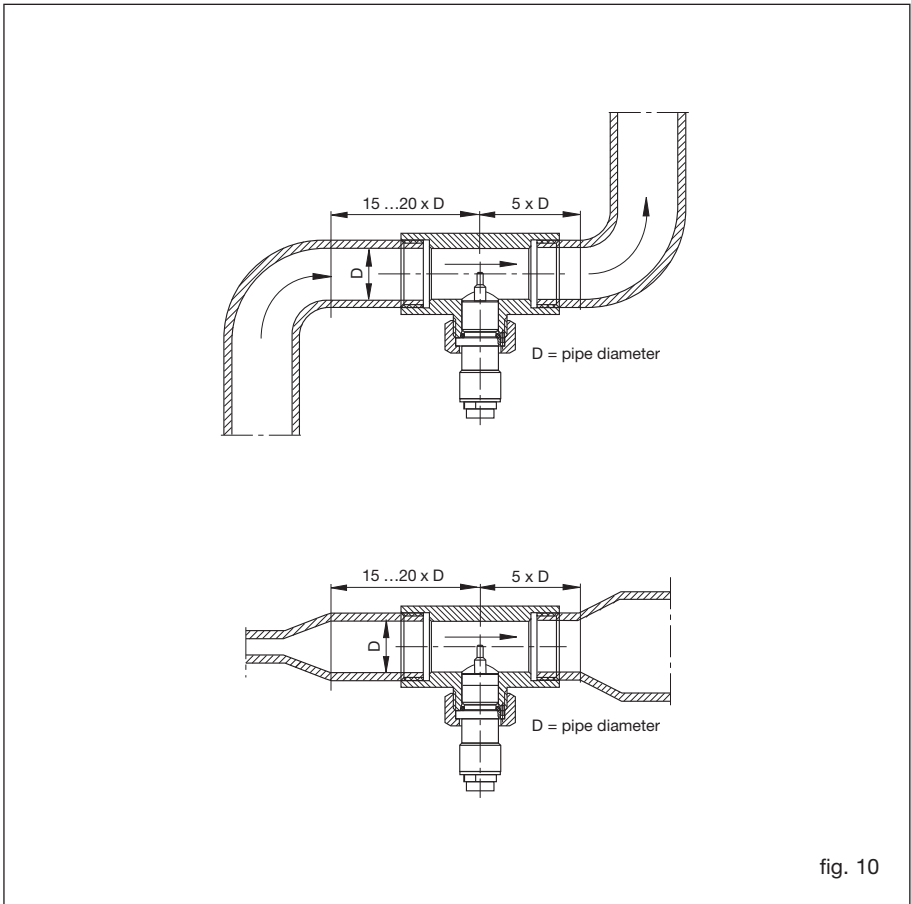
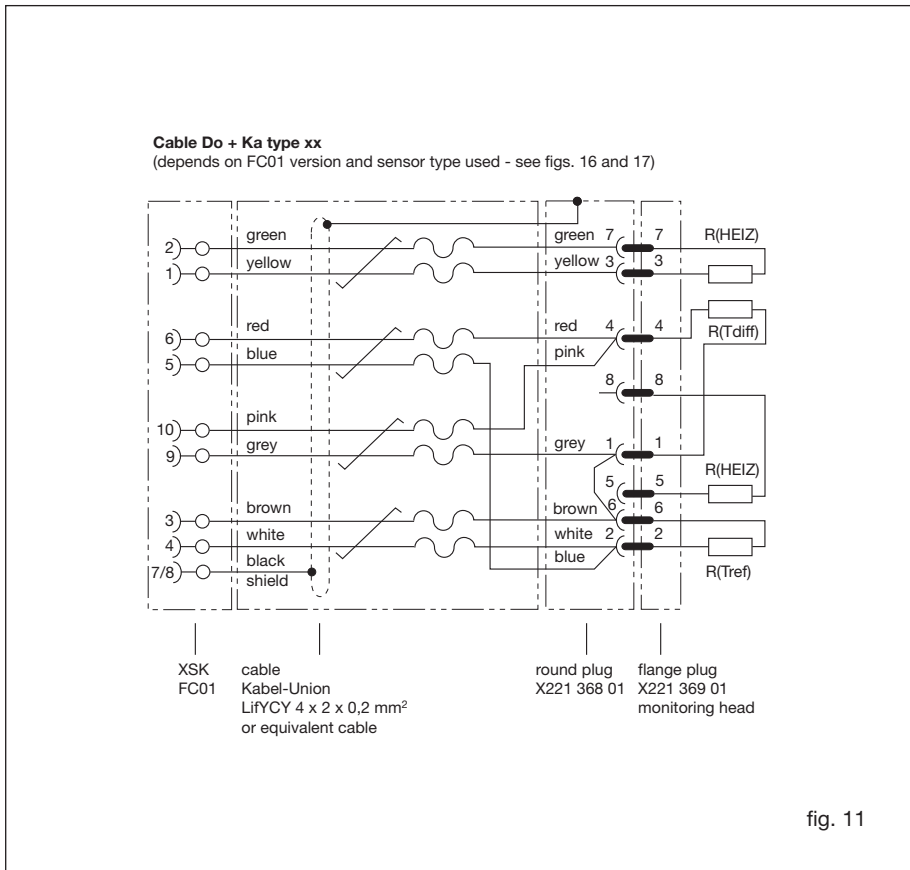

fig. 10

2.1.6 Condensate deposits

Oil or water condensates on the sensors may falsify the measuring results. Such deposits must be expected, for example, when high flow velocities of compressed air are concerned and there is no drying provided. Normal condensation on an unheated sensor is normally not realised, it will dry up after a few minutes. Deposits on heated sensors only occur at high air humidities and will cause significant measuring errors. In most cases, such deposits will dry up within a few minutes. Deposits of oil, however, will not dry up and should be removed at regular intervals.

2.1.7 Electrical connection



2.2 Installation of electronic control unit FC01-CA

2.2.1 Mechanical installation

2.2.1.1 Rail-mounted version FC01-CA-U1... (fig. 12)

- The electronic housing is mounted on a symmetric rail to EN 50022.
- For thermal reasons, the modules should be spaced by at least 10 mm.
- Removal is by releasing the spring catch.

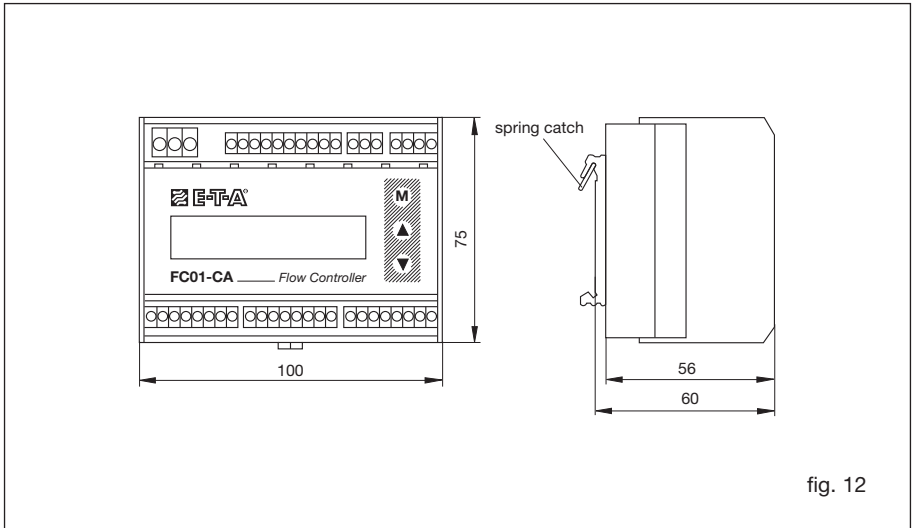

fig. 12

2.2.1.2 Surface mounted version FC01-CA-FH-U1... (fig. 13)

- Remove the cover of the housing.
- Install the housing in place using the 4 self-tapping screws M4 (see fig. 13).
- Replace the cover and tighten the retaining screws.

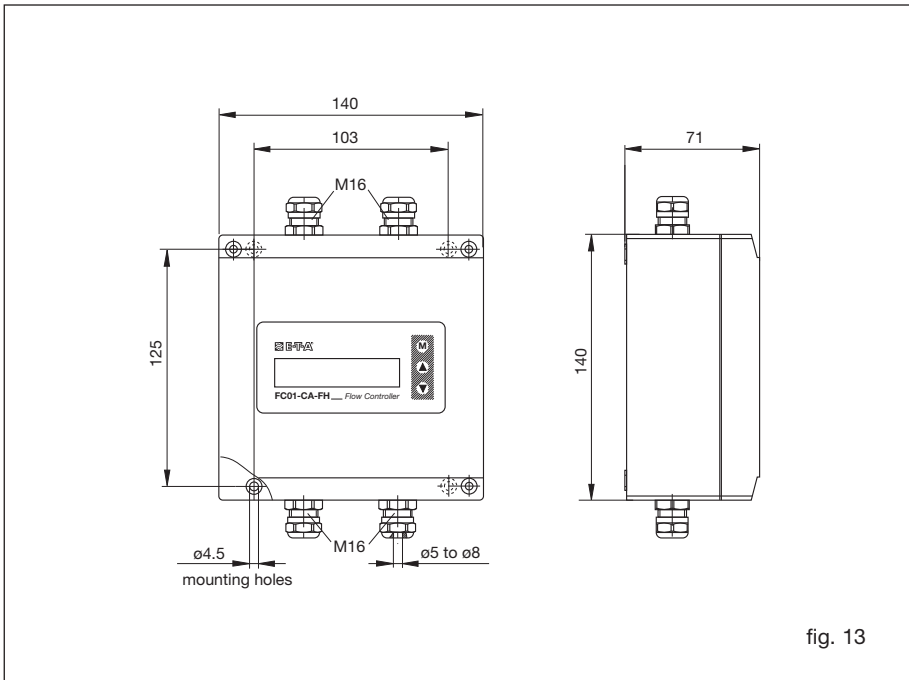

fig. 13

2.2.1.3 Front panel mounted housing FC01-CA-ST-U1... (fig. 14)

- Insert housing into front of mounting hole and fix with 4 screws (see fig. 14) from the rear.

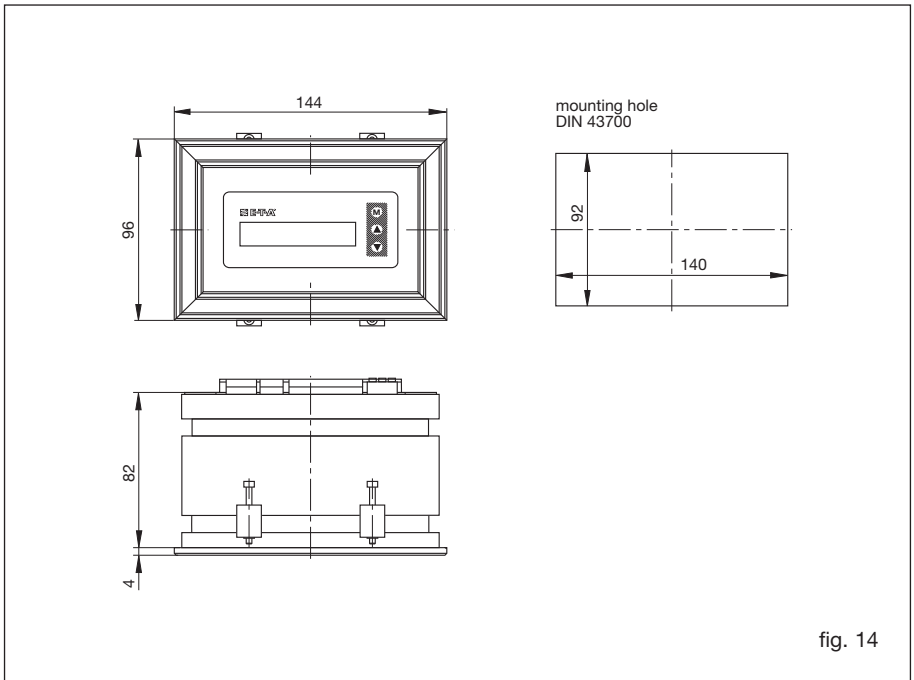

fig. 14

XAO - Analogue outputs

Connection by 8 pole connector; max. 1.5 mm²; LiYCY 2 x 0.25 mm² cable recommended for each analogue output

Pin selection for analogue outputs (option: V1, V2, C1)

Pin No.	Signal name	Function
1	NC	none
2	ANA01 ANA1GND SGNDA1	analogue output 1 - flow
3		reference potential for analogue output 1
4		shield ground for analogue output 1 (ungrounded) *
5	SGNDA2 ANA02 ANA2GND	shield ground for analogue output 2 (ungrounded) *
6		analogue output 2 - temperature
7		shield ground for analogue output 2
8	NC	none

* Apply shield on one side only.

XAH - Limit switch signal outputs - relay outputs - change over contacts

Connection by 8 pole connector; max. 1.5 mm²; LiYCY 3 x 0.38 mm² cable recommended for each signal output

Pin No.	Signal name	Function
1	SGNDL1 LIM1 LIM1COM	shield ground 1
2		non-inverted signal output 1 (N/O)
3		common change over input 1
4	/LIM1	inverted signal output 1 (N/C)
5	SGNDL2 LIM2 LIM2COM	shield ground 2
6		non-inverted signal output 2 (N/O)
7		common change over input 2
8	/LIM2	inverted signal output 2 (N/C)

XAH - Limit switch signal outputs - transistor outputs NPN, freely connectable as emitter (-) and collector (+) have been brought out separately.

Connection by 8 pole connector; max. 1.5 mm²; LiYCY 4 x 2 x 0.2 mm² cable recommended

Pin No.	Signal name	Function
1	/ERROR E /ERROR C	summarized error indication - emitter terminal
2		summarized error indication - collector terminal
3	/BUSY/PULSE E /BUSY/PULSE C	availability signal or frequency output - emitter terminal
4		availability signal or frequency output - collector terminal

5]	— [LIM2 E	limit value 2 - emitter terminal
6]		LIM2 C	limit value 2 - collector terminal
7]	— [LIM1 E	limit value 1 - emitter terminal
8]		LIM1 C	limit value 1 - collector terminal

XSK - Connection of calorimetric monitoring heads type CS_x

Pre-sized connecting cable Do+Ka type 15 or Do+Ka type 18 with plug-in screw terminal strip (see 2.1.7)

(XAS - secondary current supply)

Only for connection of cable shield (not released for user)

Pin No.	Signal name	Function
3	SGND	/shield ground

2.3.2.1 Circuit diagram FC01-CA

Version: 24 V, relay outputs

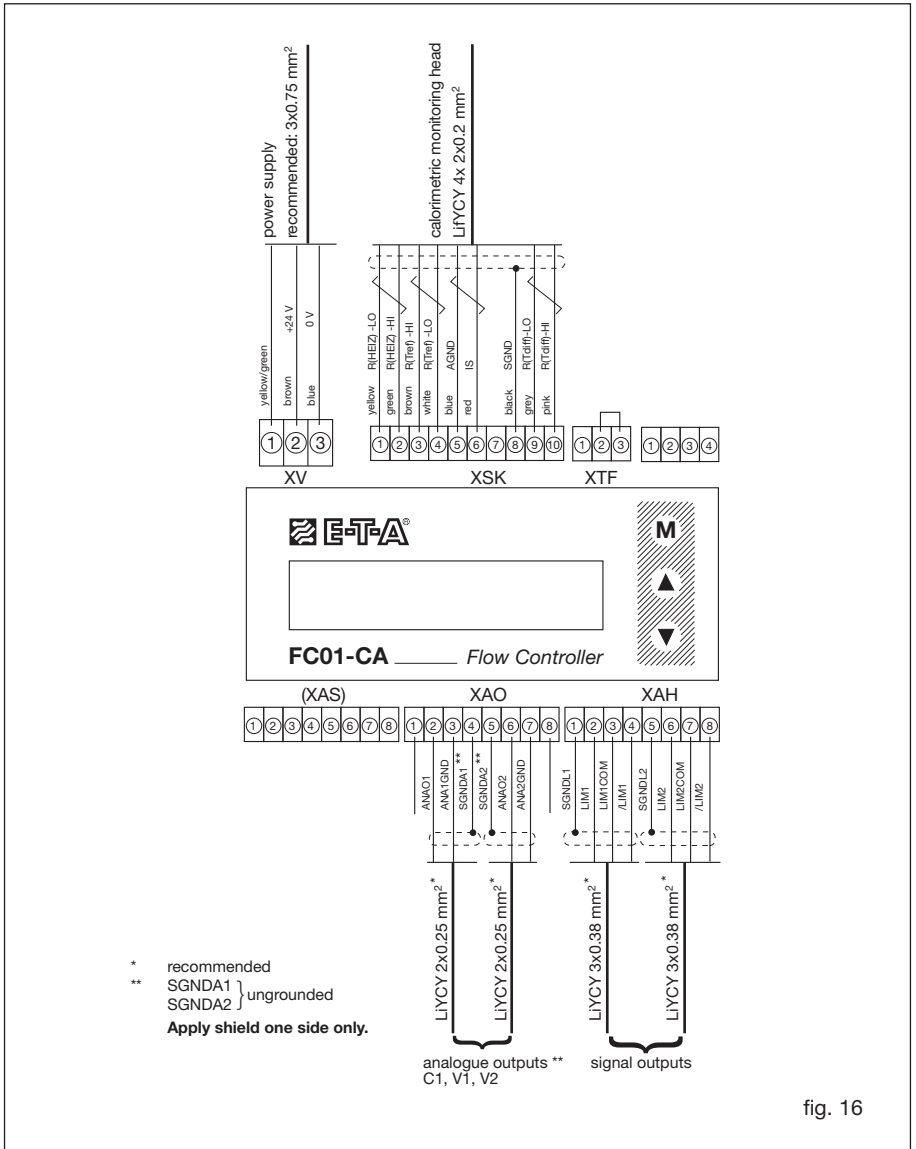
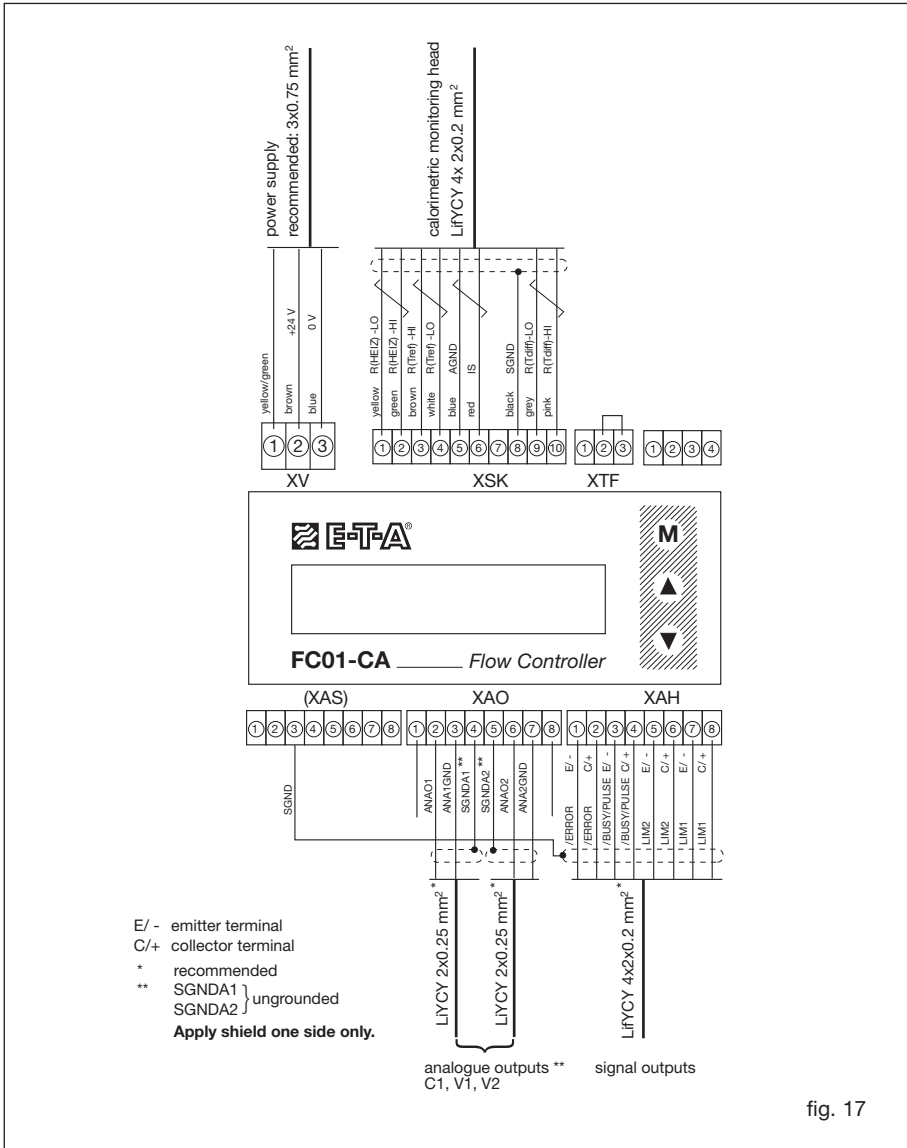

fig. 16

2.2.2.2 Circuit diagram FC01-CA

Version: 24 V, transistor outputs (NPN)



2.3.2.3 Electrical connection - frequency output (version FC01-CA-U1T4)

The quantity-dependent pulse may be selected in the menu item “DISPLAY SELECT”. A square pulse signal is available for driving a counter of a primary control at the plug **XAH** /BUSY E/- and /BUSY C/+ (pins 3 and 4) (see fig. 27 - circuit diagram FC01-CA - transistor outputs).

Signal ground shall be connected to pin 3 (BUSY E/-) and the driving load to pin 4 (BUSY C/+).

The pulse length is 50 ms ($\pm 1\%$) continuously.

Select cable size $\leq 1.5 \text{ mm}^2$ to make the connections.

The shield cables can be connected to connector **XAS**, pin 3.

Electronic signal processing (fig. 18)

If the frequency output of the FC01-CA is connected to an electronic counter, computer or PLC, the load current should not exceed 10 mA so as to ensure low level is 0.8 V. The max. admissible voltage level of 48 V is irrelevant in this connection.

Typical circuit (example 1)

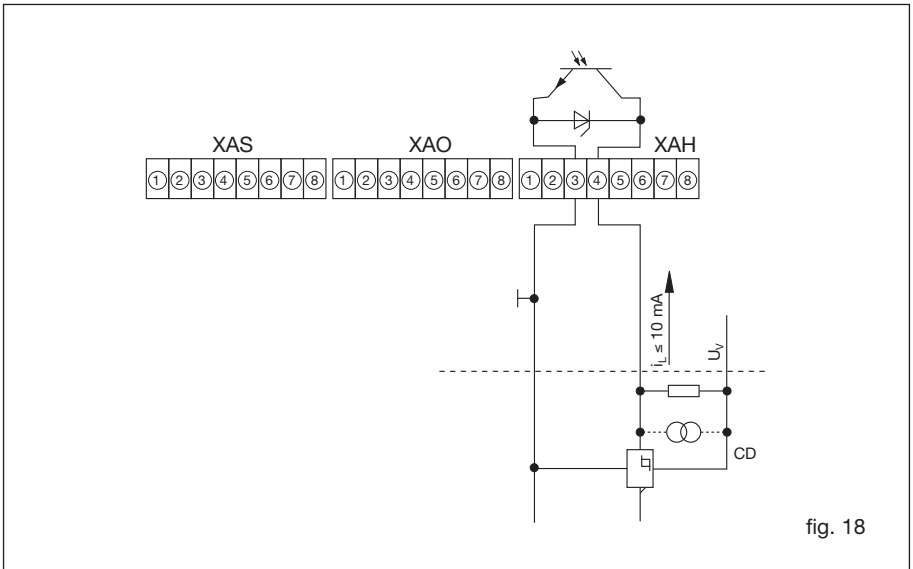

fig. 18

Electromechanical pulse counter (fig. 19)

The FC01-CA driver output comprises an integral safety circuit which when isolating the counter operating coil will limit overvoltages caused by inductance and convert the energy stored.

The counter should be able of processing a counting frequency of ≥ 10 Hz as the pulse length is 50 ms ($\pm 0.1\%$) continuously.

It should therefore be ensured that the counter can be increased by one during the time available
 If a separate relief network is preferred to the integral network, care should be taken when processing the max. frequency of 10 Hz to ensure the energy stored in the operating coil has dissipated by the time the counter output is reset. The time to do this should be below 40 ms, making due consideration to switching times and pulse variations.

Typical circuit (example 2)

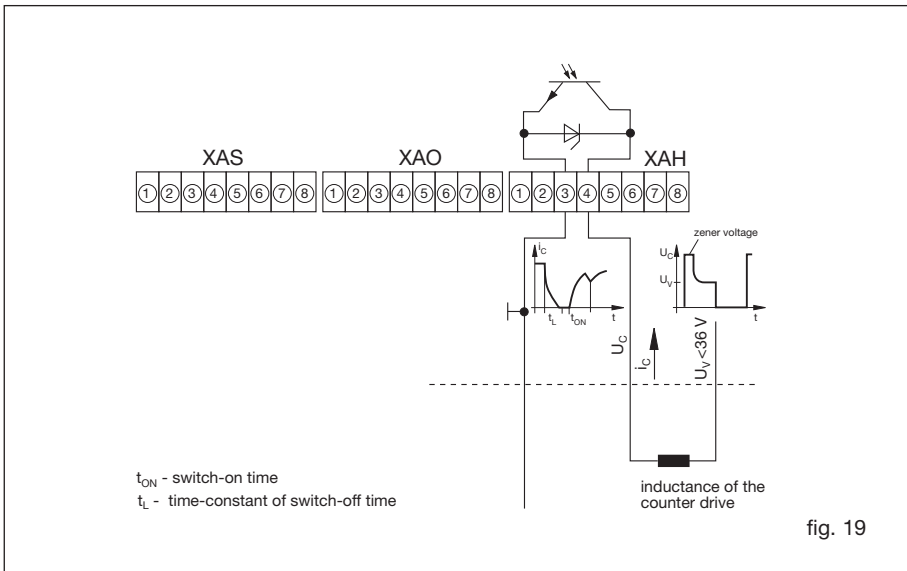

Note:

- As there will be a reset pulse available at the output in the moment the supply voltage of the FC01-CA is applied, make sure that the counter is switched on delayed or set to zero after it has been switched on.

3 Operating system

Clear menu-driven control, via keyboard and display, enables easy definition of parameters and configuration. This provides high system flexibility, making the FC01-CA the optimum solution for a wide variety of measuring, monitoring and display tasks.

When programming the FC01-CA the user is guided by plaintext in the display through menus in which he may enter or select the required functions.

All functions are distributed on the three following menu levels:

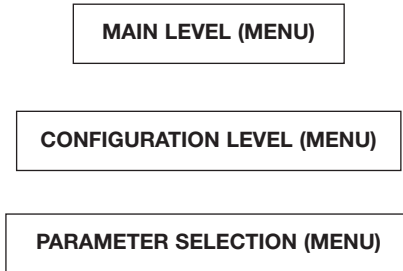

See Appendix 2 listing all functions available.

Keypads (M) MODE, (▲) UP and (▼) DOWN

Setting and configuration is by means of three front keypads (M) MODE, (▲) UP and (▼) DOWN. It is also required for setting the unit to simultaneously press (▲) UP and (▼) DOWN = (▲+▼).

Caution!

! The FC01-CA can only be set or operated when connector XTF (keyboard release) is removed!

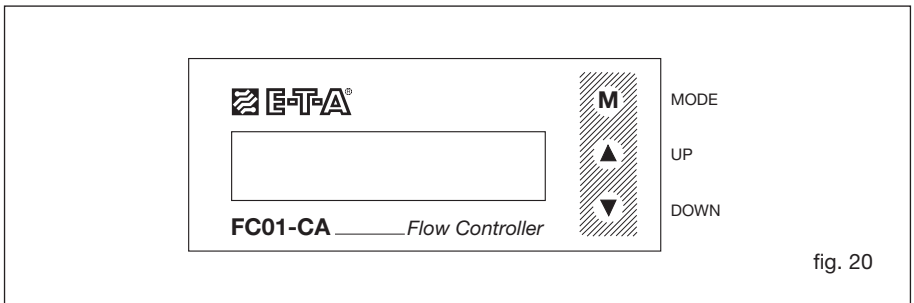

fig. 20

Menu paging

The next menu option is selected by pressing **(M)** MODE (forward paging).

Pressing **(M)** MODE after the last menu option will cause skipping to the first option of the menu.

Calling a menu option

Simultaneously pressing **(▲)** UP and **(▼)** DOWN = **(▲ + ▼)** calls the selected menu option, or causes skipping to the selected submenu.

Entry of numerals

Some menu options require numerical values to be entered. After selecting the appropriate menu option, the value indicated can be changed by pressing **(▲)** UP or **(▼)** DOWN.

Each time **(▲)** UP or **(▼)** DOWN are pressed, the value indicated will be increased and reduced respectively, by one numeral skip.

The longer **(▲)** UP or **(▼)** DOWN are pressed, the faster the increase or reduction.

Transfer of entries

Pressing **(M)** MODE transfers the set value or the selected menu option to a volatile memory.

A permanent transfer of settings and values is only effected when quitting the menu, after a plausibility check of all entries.

Afterwards the data are still available even after repeatedly switching the FC01-CA ON/OFF.

Deleting data

Selected data such as MIN or MAX values can be deleted or reset by simultaneously pressing

(▲) UP and **(▼)** DOWN = **(▲ + ▼)**.

Caution!



After configuration and parameter selection re-connect plug **XTF** (keyboard release) to protect the system against unauthorised access!

4 Operation and main menu

4.1 Switch-on performance

Upon power application **POWER ON TEST** will be shown on the display for approx. 2 sec., with the **software version number** being indicated in the second line.

During this period, the integral controller will conduct test routines (see para. 7.1, Test and diagnosis).

If during the test no error was found, the display will indicate either **HEATING UP**.

The FC01-CA will then be in the heating up period required for the measuring procedure.

4.2 Measuring cycle

Upon completion of the heating up period (only applicable to calorimetric sensors) and availability of the first measured value, the display will change to measuring cycle, and the user interfaces such as analogue outputs or limit switches will be up-dated.

Note:

- It is not possible to configure or select parameters of the system during the measuring operations!

All options of the main menu may be addressed without affecting the measuring and monitoring function.

Menu option values

PEAK VALUE MIN
PEAK VALUE MAX
LAST ERROR
TOTALISATOR

may be deleted simultaneously operating the  UP and  DOWN =  switches without affecting the measuring operations.

Over limits of the measuring range

Theoretically established measuring values will be used when the measuring range of calorimetric monitoring heads is exceeded (0 ... 68 m/s). The FC01-CA can thus be operated beyond the measuring values defined, i.e. up to 100 m/s.

Above 100 m/s the error message „ERROR 30“ indicates exceeding of the display range.

This feature will not affect the accuracy specified for the measuring ranges defined whilst no accuracy information can be given for conditions where the measuring ranges are exceeded.

Analogue output, limit switches etc. can be set beyond the measuring range. When per cent display is selected, the defined measuring range will correspond to 0 ... 100% (>100% when the defined range is exceeded).

The following operating data may be retrieved in the main menu during the measuring cycle: (see para. 4.2.1)

4.2.1 Operating data

4.2.1.1 Measured value(s)

Flow rate and medium temperature (not with turbine-type sensor) are indicated by the units selected in the upper line of the LC display.

The lower line of the display will optionally show the switching condition of the limit switches and an analogue bar with a 10-segment resolution, or the flow volume/time unit pertinent to the indicated flow rate or the totalized flow volume (totalizer function).

The analogue bar has different meanings, depending on its configuration (see para. 5.9 - menu option BARGRAPH).

The limit switches are identified according to their physical assignment, i.e. by **F** for flow rate and **T** for medium temperature, at the first or last place of the second line on the display.

If **F** and **T** are shown reversed, the limit switch is in the switch-on condition.

Limit switches lying within the analogue bar range are also represented at the appropriate place of the analogue bar (see para. 5.9).

The following figures show the display variants under menu option "Measured value(s)" (para. 5.8 - menu option DISPLAY SELECT and 5.10 - menu option FREQUENCY OUTPUT).

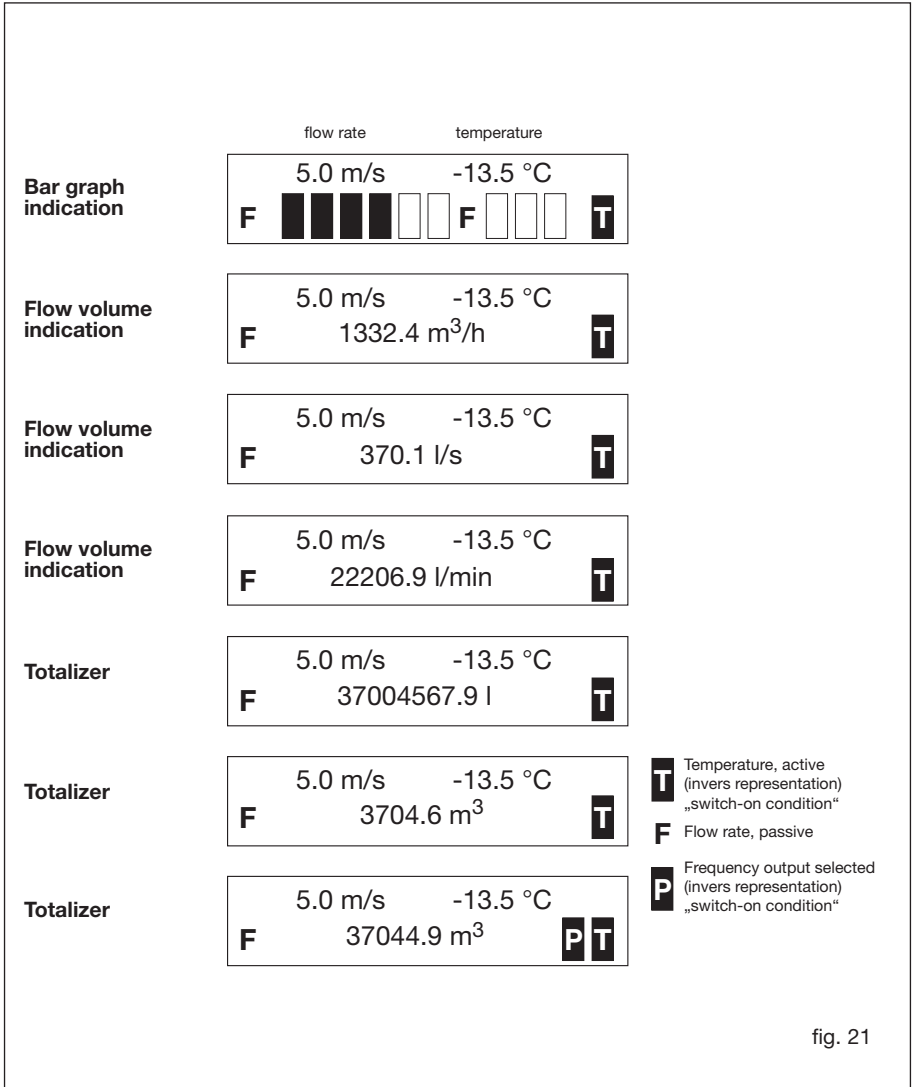

fig. 21

4.2.1.2 Peak values (menu option: **PEAK VALUE MIN / PEAK VALUE MAX**)

The FC01-CA comprises four specific measured-values memories.

They store the lowest and highest value of flow rate and medium temperature.

After switch-on or NOT-BUSY indication, the minimum and maximum values are deleted and will be continuously updated (non-return pointer principle).

The peak values may be retrieved in the main menu and are deleted by simultaneously pressing

▲ UP and ▼ DOWN = (▲ + ▼) .

Caution!

⚠ Power failure or disconnection of the power supply will delete the contents of the four measured-values memories.

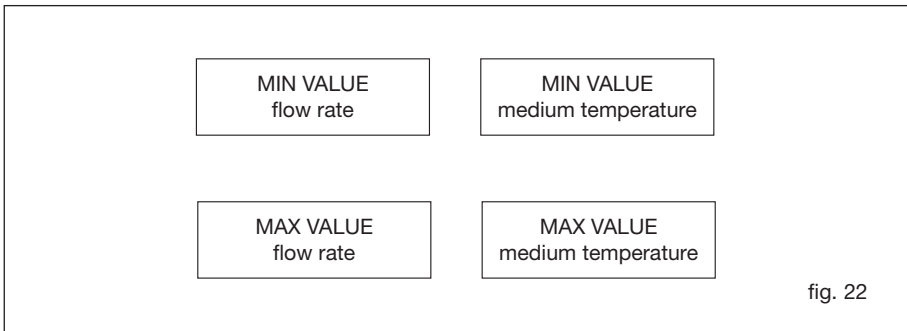

fig. 22

4.2.1.3 Low flow suppression (menu option: **ZERO SUPP.**)

The setting range for the low flow suppression option is between 1 and 10% of the measuring range final value. This means that flow volumes measured below that limit value are set at zero.

Selecting zero setting causes the current flow to be set at zero.

MIN. FLOW = xx%

4.2.1.4 Last error (menu option: **LAST ERROR**)

The last main menu option to be called is the error memory.

This error memory comprises the number of the last error (see section 7). It may be very helpful when commissioning the FC01-CA.

Other than the peak value memories described above, the contents of this memory will be retained even upon power failure.

The user may purposely delete the error memory in the condition selected by simultaneously pressing ▲ UP and ▼ DOWN = (▲ + ▼) .

4.2.1.5 Main menu

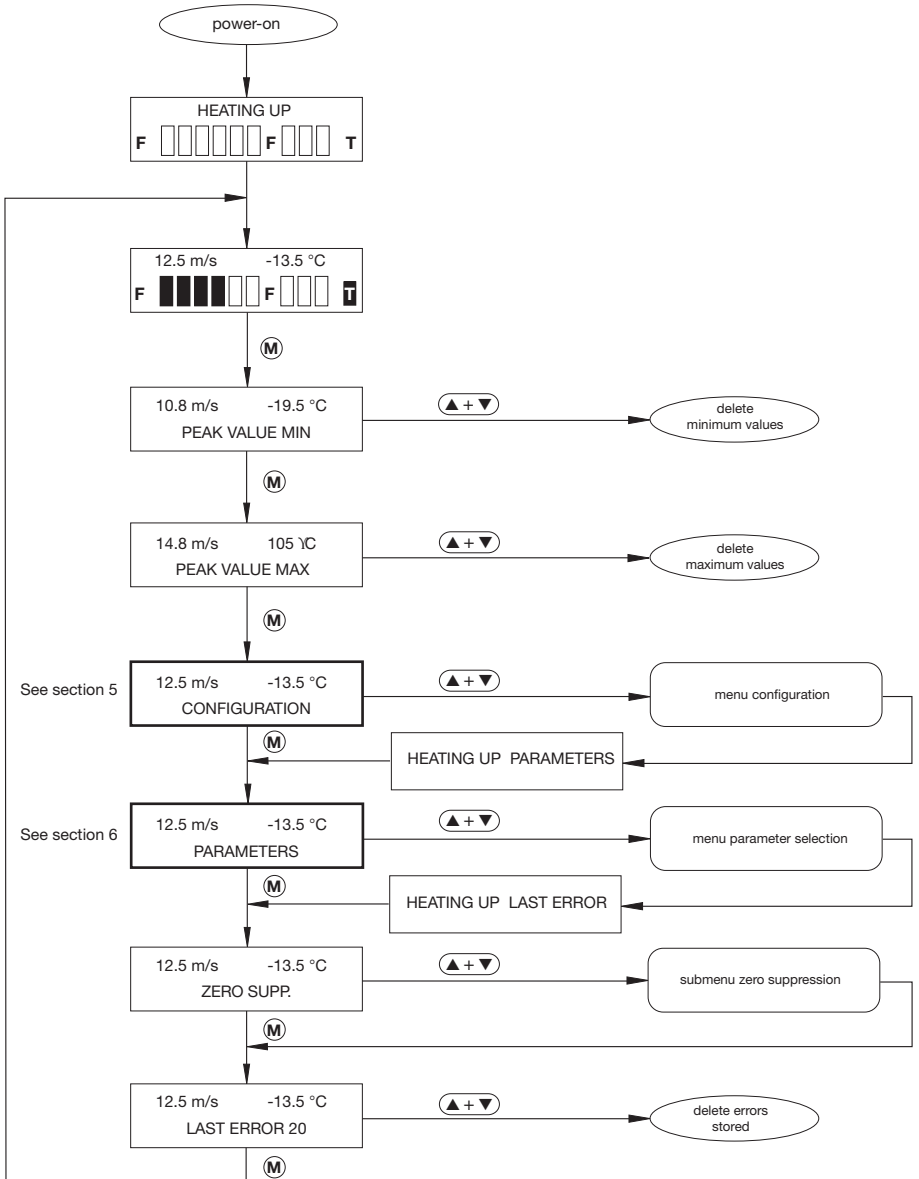

5 Configuration (menu option: **CONFIGURATION**)

The CONFIGURATION submenu serves to adjust the FC01-CA to its application.

During system configuration, measuring operations are not possible (see Appendix 1).

Configuration possibilities are:

5.1 Selection of monitoring head (menu option: **SENSOR SELECT**)

This menu option allows the selection of the monitoring head types suitable for compressed air applications, that can be used with the FC01-CA (issue 04.2004).

The appropriate sensor can be selected from the following menu (for type designation see type label or CPI catalogue).

- TYPE CSP-11AM1BV insertion head with ball valve
- TYPE CSP-11AM1 insertion head with sensor adapter TP-..
- TYPE CSF-11AM1 push-in monitoring head
- TYPE S-No. xxx custom designed monitoring head

Note:

- Monitoring head S-No. xxx is only available where a custom designed option has been ordered and integrated.

Caution!



Menu option SENSOR SELECT may influence data in the parameter selection menu (see para. 5.13, Quitting the configuration menu).

- This menu option also allows to enter the **C** and **T** values ensuring the exchangeability of the monitoring heads.
- Pipe diameter assignment as required for volume flow measurements should also be entered.

Enter the following characteristics when selecting a **CSF monitoring head**. The setting is menu driven:

1. SENSOR CODE C xxx range: **001 ... 999**
2. SENSOR CODE T xxx range: **500 ... 999**

These characteristics are marked on the monitoring head.

Caution!



Observe correct settings as they have a major influence on measuring accuracy.

- PIPE SIZE (DIAM. = xxx.xx mm) range: **10.0 ... 999.9** mm for monitoring head CSF

Enter the following characteristics when selecting a **CSP monitoring head with ball valve**:

1. SENSOR CODE C xxx range: **001 ... 999**
2. SENSOR CODE T xxx range: **500 ... 999**

The nominal diameter of the ball valve is selected in menu option BV SIZE SELECT.

Available sizes are:

- DN25 (1 in), DN32 (1 1/4 in), DN40 (1 1/2 in), DN50 (2 in).

Enter the following characteristics when selecting a **CSP monitoring head with sensor adapter TP-...**

1. SENSOR CODE C xxx range: **001 ... 999**
2. SENSOR CODE T xxx range: **500 ... 999**

The internal diameter of the sensor adapter is selected in menu option TYPE SELECT.

Available sizes are:

- TP01 (1/2 in)
- TP02 (3/4 in)
- TP03 (1 in)
- TP04 (1 1/4 in)
- TP05 (1 1/2 in)
- TP06 (2 in)

5.2 Pressure range (menu option: **PRESS. RANGE**)

Pressure indication serves to correct the measured value and to convert standard volume flow to operating volume flow (see measuring procedure).

Setting range: **0.50 ... 250 bar / 7.35 ... 3675 PSI** (absolute pressure)

Caution!



It is imperative to consider the approved pressure resistance of the sensors and adapters used.

5.3 Volume flow measuring mode (menu option: **OPERAT. MODE**)

Standard volume flow can be indicated either as:

- **STANDARD FLOW** Standard volume flow equals operating volume flow at 1,013 mbar/14.89 PSI and 0 °C

or as

- **OPERATING FLOW** Operating volume flow is calculated by the standard volume flow, considering the pressure set (para. 5.2) and the medium temperature

The physical details are described in para. 1.1, Measuring procedures. The following volume flow and velocity values and those indicated on the display are set to standard and operating conditions by this setting.

Caution!



As under normal operating conditions pressure changes may arise, which cannot be taken into account when calculating operating volume flow, it is recommended to prefer the standard flow setting.

5.4 Gas selection (menu option: **GAS SELECT**)

This menu option allows the selection of the following gases:

- AIR
- OXYGEN O₂
- ARGON Ar
- NITROGEN N₂
- CARBON DIOXIDE CO₂
- METHANE/NATURAL GAS CH₄

Caution!



Under unfavourable conditions ignitable gas mixtures may develop. The user has to clarify whether Ex conditions are on hand and whether the corresponding requirements have to be observed.

Individual gas density is taken into account when calculating mass flow of air, oxygen and nitrogen (see DISPLAY SELECT).

Standard densities at 1.013 bar/14.89 PSI and 0 °C:

air	1.293 kg/Nm ³
oxygen	1.429 kg/Nm ³
nitrogen	1.250 kg/Nm ³

For the medium carbon dioxide (CO₂) a characteristic curve determined in our lab has been stored, which has been released for the adapters TP-01 ... TP-04.

This menu option allows the addition of other gases as required by customer.

5.5 Limit switch combinations (menu option: **LIMIT SWITCHES**)

The FC01-CA comprises two limit switches (LS1 and LS2) which are assigned to the physical quantity/quantities to be monitored in submenu LIMIT SWITCHES.

The following combinations are available:

- LS1 F and LS2 F
 - limit switch 1 flow rate
 - limit switch 2 flow rate
- LS1 T and LS2 T
 - limit switch 1 medium temperature
 - limit switch 2 medium temperature
- LS1 F and LS2 T
 - limit switch 1 flow rate
 - limit switch 2 medium temperature
- LS1 T and LS2 F
 - limit switch 1 medium temperature
 - limit switch 2 flow rate

Mode of operation, limit value and hysteresis of the limit switches are set in menu "PARAMETER SELECTION".

Caution!



Menu option "LIMIT SWITCHES" may influence data in the parameter selection menu (see para. 5.13, Quitting the configuration menu).

5.5 Flow rate unit (menu option: **FLOW UNIT**)

At this point (1st line top left) the requested unit for the flow velocity will be set.

This menu option is used to set the desired flow rate unit:

- METRE/SEC [m/s]
- FEET/SEC [FPS]
- PERCENT [%]
- BLANK [no unit]

Any further entries relating to flow rate (e.g. limit value, analogue output etc.) refer to that unit.

Standard percent is displayed when BLANK (no unit) is selected.

When the flow rate unit is changed, all configuration and parameter data relating flow rate will automatically be converted!

5.7 Medium temperature unit (menu option: **TEMP. UNIT**)

This submenu is used to select the medium temperature unit (1st line top right).

Options are:

- GRAD CELSIUS [°C]
- GRAD FAHRENHEIT [°F]
- KELVIN [K]

All other entries relating to the medium temperature (limit value, analogue output, etc.) refer to the unit selected there. When the temperature unit is changed, all configuration and parameter data relating to medium temperature will automatically be converted.



5.8 Display (menu option: **DISPLAY SELECT**)

The FC01-CA enables the user to define the 2nd line of the display in certain points. When the first line of the LC display in the main menu indicates the flow rate in the unit selected as well as the medium temperature in °C, °F or K, it is possible to select the second line from the following menu options (see para. 5.15).

- | | |
|---|--|
| • BARGRAPH | Totalizer: |
| • LITRE/SECOND [l/s] | • LITRE [l] |
| • LITRE/MINUTE [l/min] | • METRE ³ [m ³] |
| • METRE ³ / HOUR [m ³ /h] | • FEET ³ [F ³] |
| • GALLONS ³ /MINUTE | • KILOGRAM [kg] |
| • FEET ³ /SECOND [F ³ /s] | • POUND [lb] |
| • FEET ³ /MINUTE [F ³ /min] | |
| • KILOGRAM/SECOND [kg/s] | |
| • KILOGRAM/MINUTE [kg/min] | |
| • KILOGRAM/HOUR [kg/h] | |
| • POUND/SECOND [lb/s] | |
| • POUND/MINUTE [lb/min] | |
| • POUND/HOUR [lb/h] | |

Where totalizer function has been selected, the totalizer will start at zero counting in the unit selected (litre, m³ or gallons).

When the display changes from m³ to litre or gallons, or from litre or gallons to m³, the value already counted will be converted.

The content of the totalizer is deleted by simultaneously pressing  UP and  DOWN = , or when the max. display value (99999999.9 l, m³ or gallons) is reached. In both cases, the totalizer will restart from zero.

Caution!

⚠ The content of the totalizer is deleted in the event of power failure or disconnection of the power supply!

5.9 Bar graph (menu option: **BARGRAPH**)

This menu option allows the user to set the bar graph as desired. The following settings should be made:

- FLOW / TEMP = (bar graph assignment: flow rate/medium temperature)
- ZERO = (initial value of the bar graph)
- FS = (final value of the bar graph)

Independent of its assignment, the bar graph has a constant resolution of 10 segments.

When entering the initial or final value, the user should observe reasonable resolution!

The bar graph also comprises the representation of the limit switch(es) as far as they can be indicated in the bar range selected.

The representation of the limit switches in the bar graph depends on the switch-on value of the limit switch.

For representation details see para. 4.2.1 (Operating data).

Example:

Limit switch assignment: LS1 F and LS2 T
 Switch-on value LS2: 23 °C
 Switch-off value LS2: 29 °C
 Analogue bar graph assignment: medium temperature
 Initial value - analogue bar graph: 20 °C

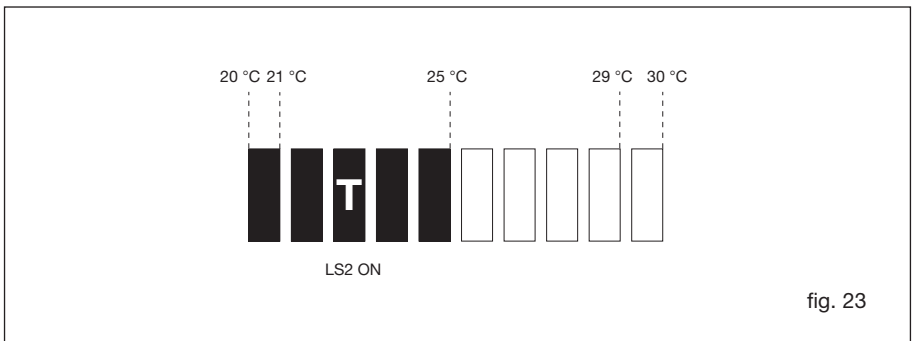

Final value - analogue bar graph: 30 °C

Instantaneous temperature value: 25 °C

→ resulting in the analogue bar graph display shown below:

5.10 Frequency output (menu option: **FREQUENCY OUTPUT**)

The totalizer function of the FC01-CA has been expanded by the output of **proportional quantity pulses**. The function can only be displayed by version **FC01-CA-U1T4** (transistor outputs).

The proportional quantity pulses have been determined as follow:

1 pulse / quantity (totalizer unit selected)

Example:

1 pulse / 10.0 [litre]

The frequency output will supply 1 pulse per 10 litres (totalized quantity).

When the quantity-proportional pulses are assigned, the frequency of the frequency output must not exceed 10 Hz. The limits that can be displayed are determined by the flow velocity range and the pipe diameter.

Potential setting range of the frequency output: 1 pulse per 0.1 ... 999.9 [litre], [m³], [gallons]

Behaviour of the frequency output when the max. frequency is exceeded

The max. frequency being exceeded will not cause the measurement to stop but will rather cause the error output to signal error 60 on the display. This error is included in priority group III.

If a combination of priority III errors occurs simultaneously, they are indicated or stored in the error memory observing the following sequence:



Error No. 20, 30, 60, 40, 41.

Behaviour of the frequency output when the measurement is stopped

When the measurement is stopped (as caused by priority II error and calling the configuration or parameter selection menus), the pulses for the quantity already counted will be available. Thereafter the output of pulses will be stopped, with the frequency output becoming high-resistive until the measurement is restarted.

Behaviour of the frequency output when the content of the totalizer is deleted

The content of the totalizer may be deleted by simultaneously pressing  UP and  DOWN

=  +  in the main menu.

As the frequency output refers to the content of the totalizer, although its operation is not

dependent on the content of the totalizer, a totalized quantity that is smaller than that set per pulse will not be lost.

This means that only the content of the totalizer is deleted.

5.11 Analogue output - flow rate (menu option: **ANA OUT FLOW**)

This menu option allows adjustment of the flow rate analogue output specifically to the requirements of the entire system.

Options are:

- OFFSET = 0%/20% FS (0/4 ... 20 mA, 0/1 ... 5 V, 0/2 ... 10 V)
- ZERO = (initial value 0(20) % corresponds to a flow rate of _ [m/s] [%] [FPS])
- FS = (final value 100% corresponds to a flow rate of _ [m/s] [%] [FPS])

When entering the initial or final value, the user should observe a reasonable resolution!

With a flow volume/time unit selected in menu DISPLAY SELECT and when setting the initial and end values, the pertinent flow volumes will also be indicated.

5.12 Analogue output - medium temperature (menu option: **ANA OUT TEMP.**)

In conformance with the configuration "Flow rate analogue output" it is possible to adjust the medium temperature analogue output to the requirements of the entire system.

Options are:

- OFFSET = 0%/20% FS (0/4 ... 20 mA, 0/1 ... 5 V, 0/2 ... 10 V)
- ZERO = (initial value 0(20) % corresponds to a medium temperature of ... [°C] [°F] [K])
- FS = (final value 100 % corresponds to a medium temperature of ... [°C] [°F] [K])

When entering the initial or final value, the user should observe a reasonable resolution!

5.13 Quitting the configuration menu

Upon configuration of the analogue outputs, the menu may be quitted or re-set to the start (SENSOR SELECT).

To quit the configuration menu, the controller will check the data entered for plausibility.

"CONFIG. OK!" is indicated when the data are found to be correct. The menu may than be quitted by pressing **(M)** MODE.



Errors found during the plausibility check are indicated in the following sequence of priority.

Priority of entry errors in the CONFIGURATION menu:

- ERR. SENSOR SEL. SENSOR <> GAS
(the selected sensor has not been released for this application)
- ERR. A-OUT FLOW OUT OF RANGE
(flow analogue output outside measuring range)
- ERR. A-OUT FLOW ZERO ≥ FS

(initial value \geq final value with flow analogue output)

- ERR. A-OUT TEMP. OUT OF RANGE
(temperature analogue output outside measuring range)
- ERR. A-OUT TEMP. ZERO \geq FS
(initial value \geq final value with temperature analogue output)
- ERR. BARGRAPH OUT OF RANGE
(bar value outside measuring range)
- ERR. BARGRAPH ZERO \geq FS
(bar initial value \geq bar final value)

The menu can only be quitted after correction of the error(s). To do this, return to the beginning of the configuration menu by pressing  UP or  DOWN and select the menu option with the incorrect entry for correction.

Caution!



If during the configuration data are affected which are accessible in the parameter selection menu, (which may be the case for the options Sensor Selection, Medium Selection and limit Switch Assignment), the option "PARAMETERS" in the main menu will be flashing.

In this event it is imperative to branch into parameter selection menu to set the data in conformance with the desired application.

Example: Changing the limit switch assignment from **LS1 F / LS2 T** to
 LS1 F / LS2 F

Effects on
parameter data: **LS2 ON** = 0.00
 LS2 OFF = end of measuring range (depending on the medium selected)

Reason: Changing the physical assignment of limit switch 2 will adjust its switch-on and switch-off values to the new assignment (flow rate).

An overview of the configuration menu and a summary of the measuring ranges and menus available for the sensor type selected are shown on the following pages.

5.14 Configuration menu

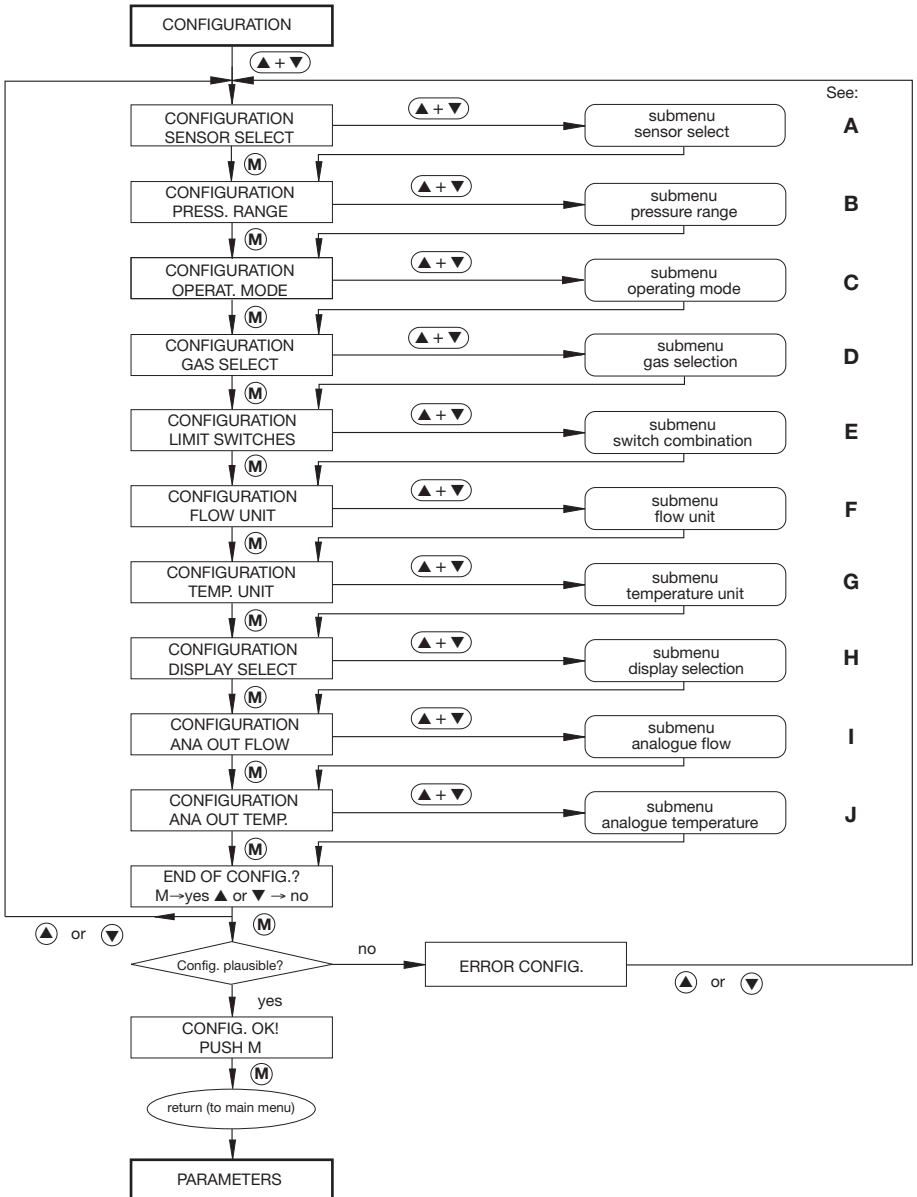

5.15 Configuration submenus

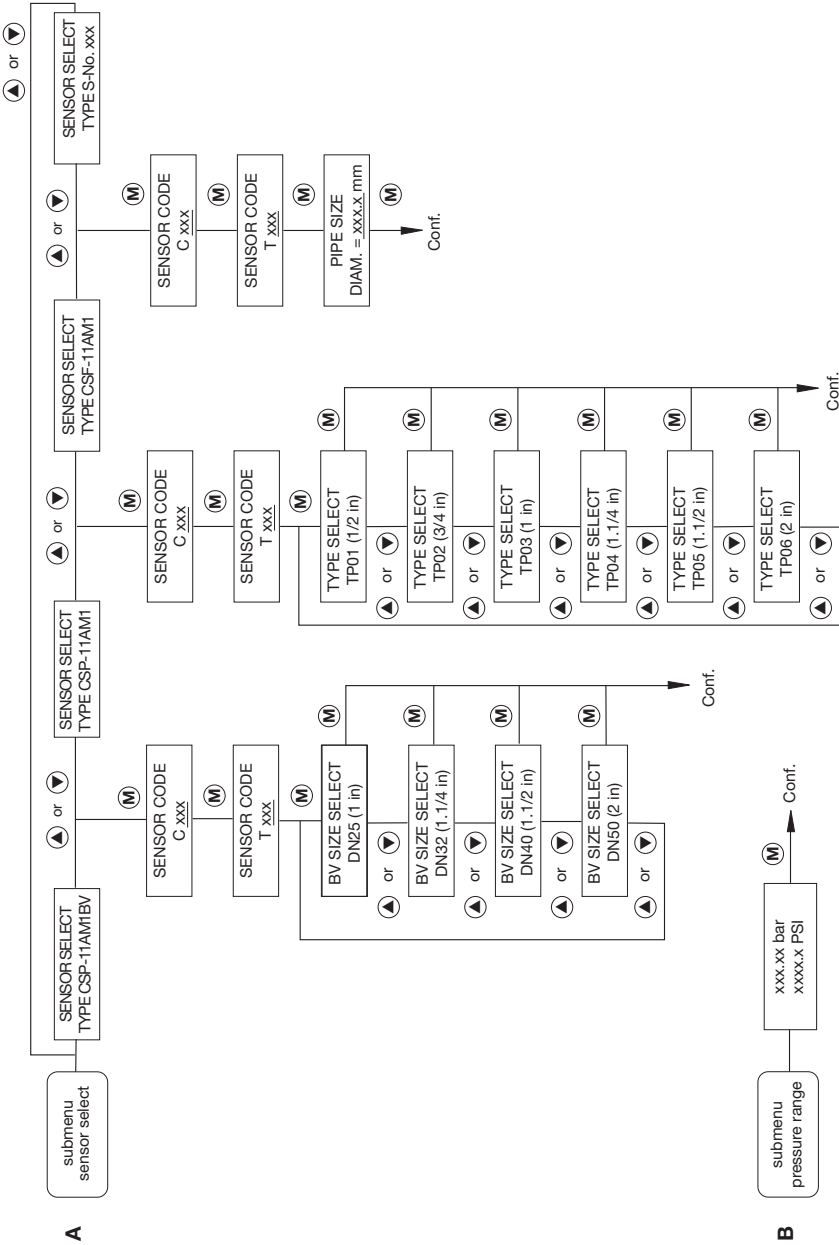

Conf. → return to configuration menu

Configuration submenus (cont'd)

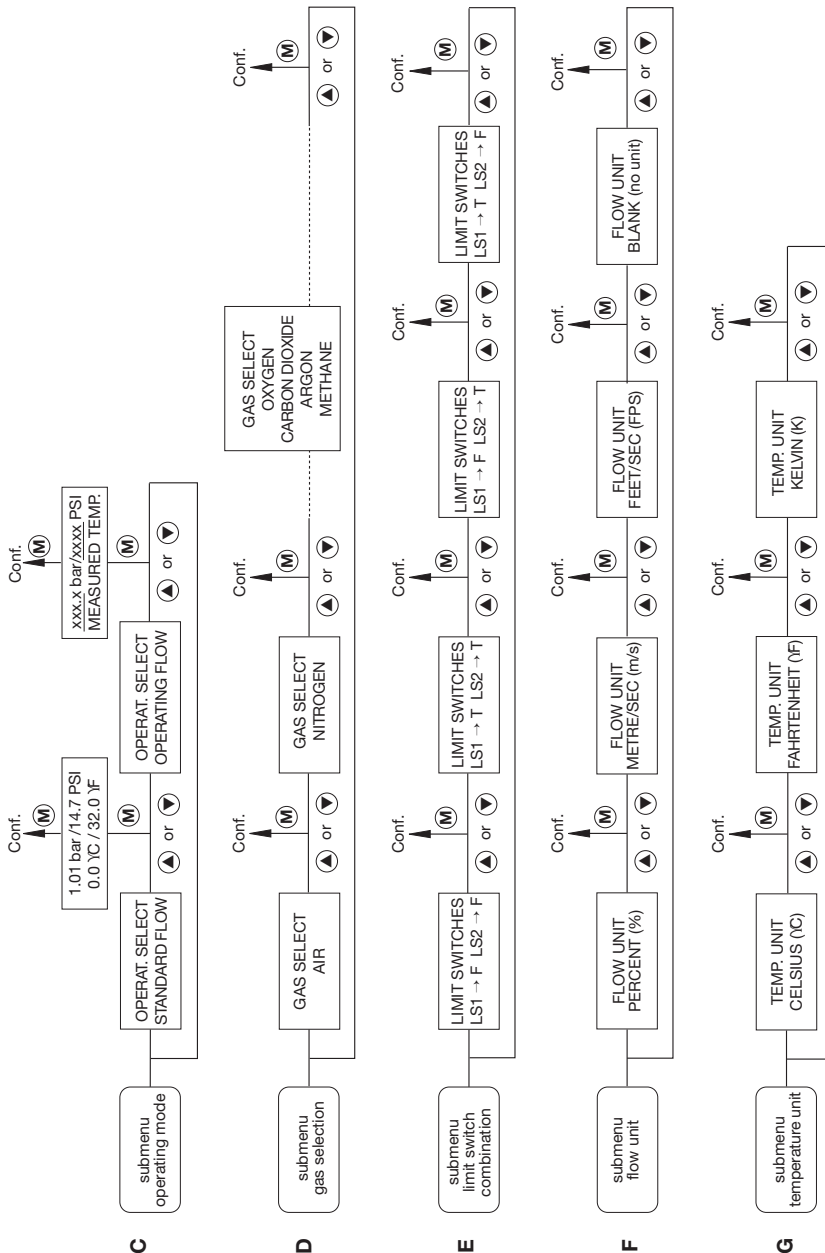

Conf. → return to configuration menu

Configuration submenus (cont'd)

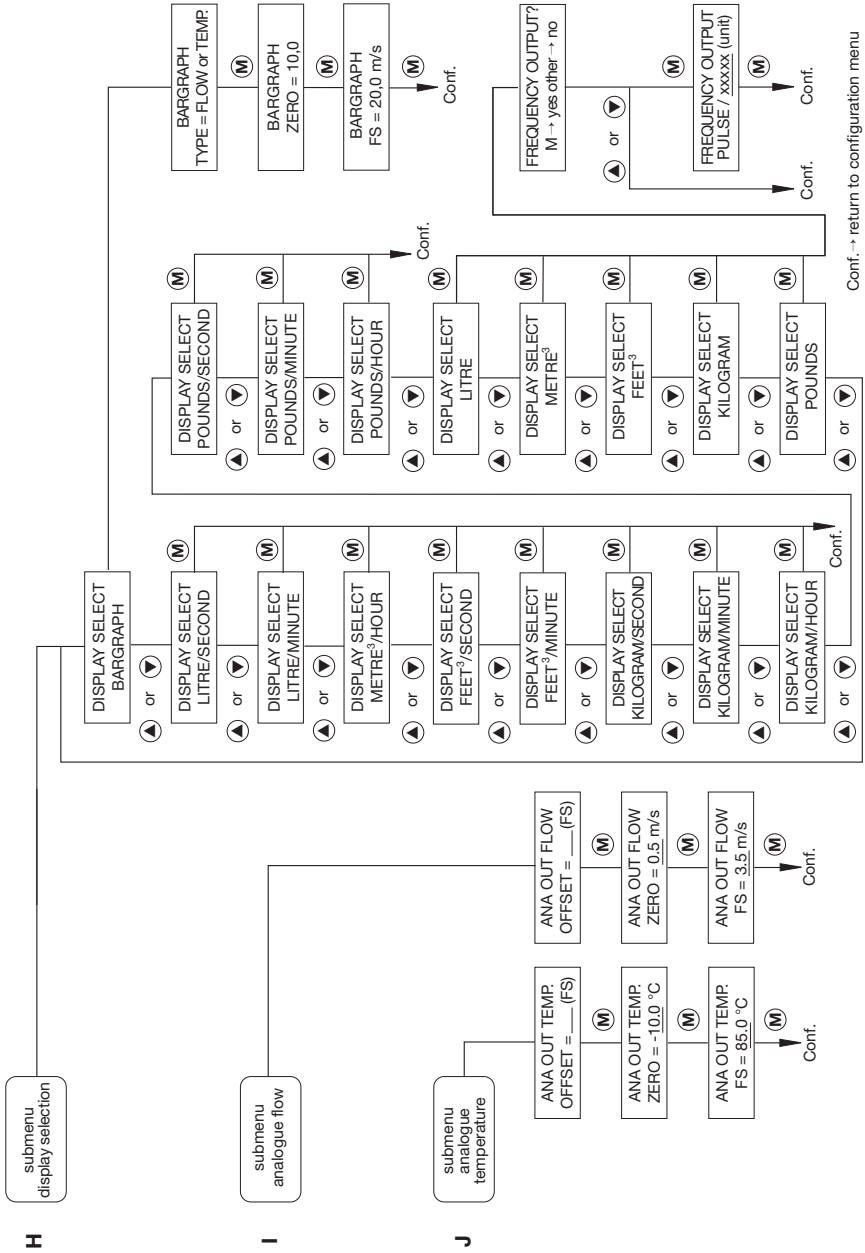

6 Parameter selection (menu option: **PARAMETERS**)

After configuration of the FC01-CA in conformance with its application (configuration menu), it is possible to set parameters (e.g. limit values).

During parameter setting, measuring operations are not possible (see Appendix 1).

The following parameters may be set in the parameter selection submenu:

6.1 Measuring time (menu option: **MEAS. TIME**)

The measuring time may be between 1 and 30 sec., referring both to flow rate and medium temperature.

The effect of the measuring time may be compared to that of a filter; it is used to determine the average of the last measured values after each measurement.

The set measuring time does not influence the measuring rate and display up-date.

6.2 Limit switch 1 - switch-on value (menu option: **LS1 ON =**)

Limit switch 1 - switch-off value (menu option: **LS1 OFF =)**

Depending on the configuration (see configuration menu) limit value 1 may be set either for flow rate or medium temperature.

The limit value may be set over the entire measuring range and is always related to the display value.

Limit switch up-date is by measuring rate, independent of the set measuring time.

The hysteresis is determined by entering different switch-on and switch-off values. Its magnitude should be reasonably adjusted to current operating conditions.

A specific definition of the operation (closed-current or open-circuit principle) may be dropped by separately entering the switch-on and switch-off value of the limit switch, because the definition is deduced from the switch-on and switch-off value.

Example 1: Switch-on value lower than switch-off value

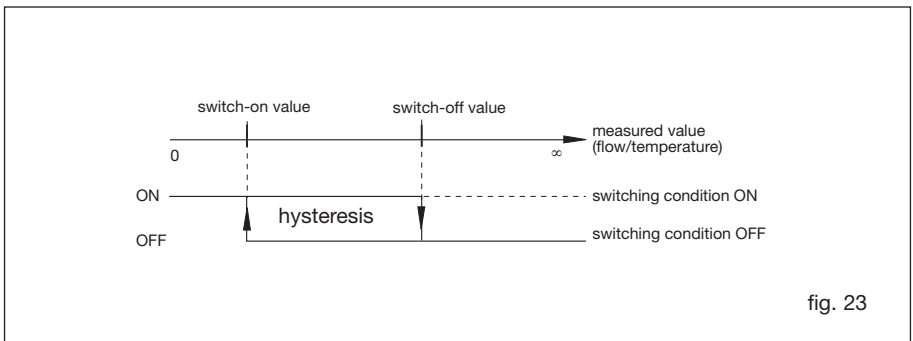

fig. 23

Example for ON:

FC01-CA with relay outputs (option R2):

- LIM1 - LIM1COM = closed
- /LIM1 - LIM1COM = open

FC01-CA with transistor outputs (option T4):

- LIM1E - LIM1C = switched

Example 2: Switch-on value higher than switch-off value

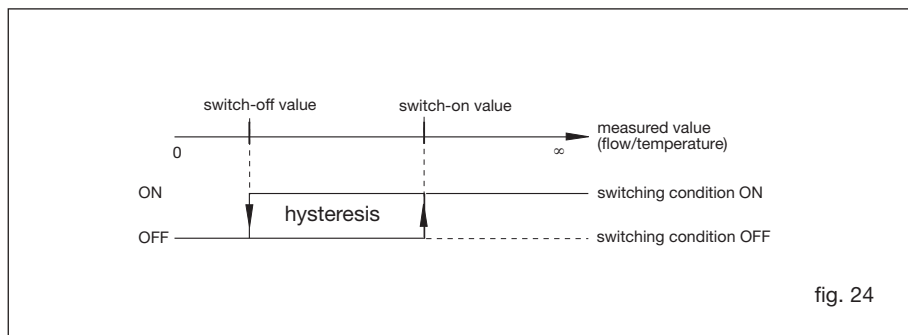

fig. 24

Example for ON: as described in example 1 (fig. 23)

With limit switch 1 set for flow rate and a flow volume/time unit selected in menu DISPLAY SELECT, and when setting the switch-on and switch-off value, the pertinent flow volumes will also be indicated.

6.3 Limit switch 2 - switch-on value (menu option: **LS2 ON =**)

Limit switch 2 - switch-off value (menu option: **LS2 OFF =**)

See limit switch 1!

6.4 Scaling factor (menu option: **FLOWSCALE**)

The scaling factor influences flow rate indication.

The factor, which may be set between 0.01 and 9.99, allows flow rate indication changes (increasing or reducing the measured value in the display).

For example, the scaling factor may be used to indicate the average flow rate in the pipeline rather than that available at the sensor.

6.5 Quitting the parameter selection menu

Before the parameter selection menu can be quitted, the controller will conduct a plausibility check of the data entered.

“PARAMETERS OK!” is indicated when the data are found to be correct. The menu may then be quitted by pressing **(M)** MODE.

Errors found during the plausibility check are indicated in the following sequence of priority.

Priority of entry errors in the PARAMETER SELECTION menu:

- ERROR LS1 OUT OF RANGE
 switch-on and/or switch-off value for limit switch 1 outside measuring range
- ERROR LS2 OUT OF RANGE
 switch-on and/or switch-off value for limit switch 2 outside measuring range
- ERROR LS1 ON = OFF
 switch-on value for limit switch 1 equals switch-off value for limit switch 1
- ERROR LS2 ON = OFF
 switch-on value for limit switch 2 equals switch-off value for limit switch 2

The menu can only be quitted after correction of the error(s). To do this, return to the beginning of the parameter selection menu by pressing **(▲)** UP or **(▼)** DOWN and select the menu option with the incorrect entry for correction.

An overview of the parameter selection menu is shown on the following page.

6.6 Parameter selection menu

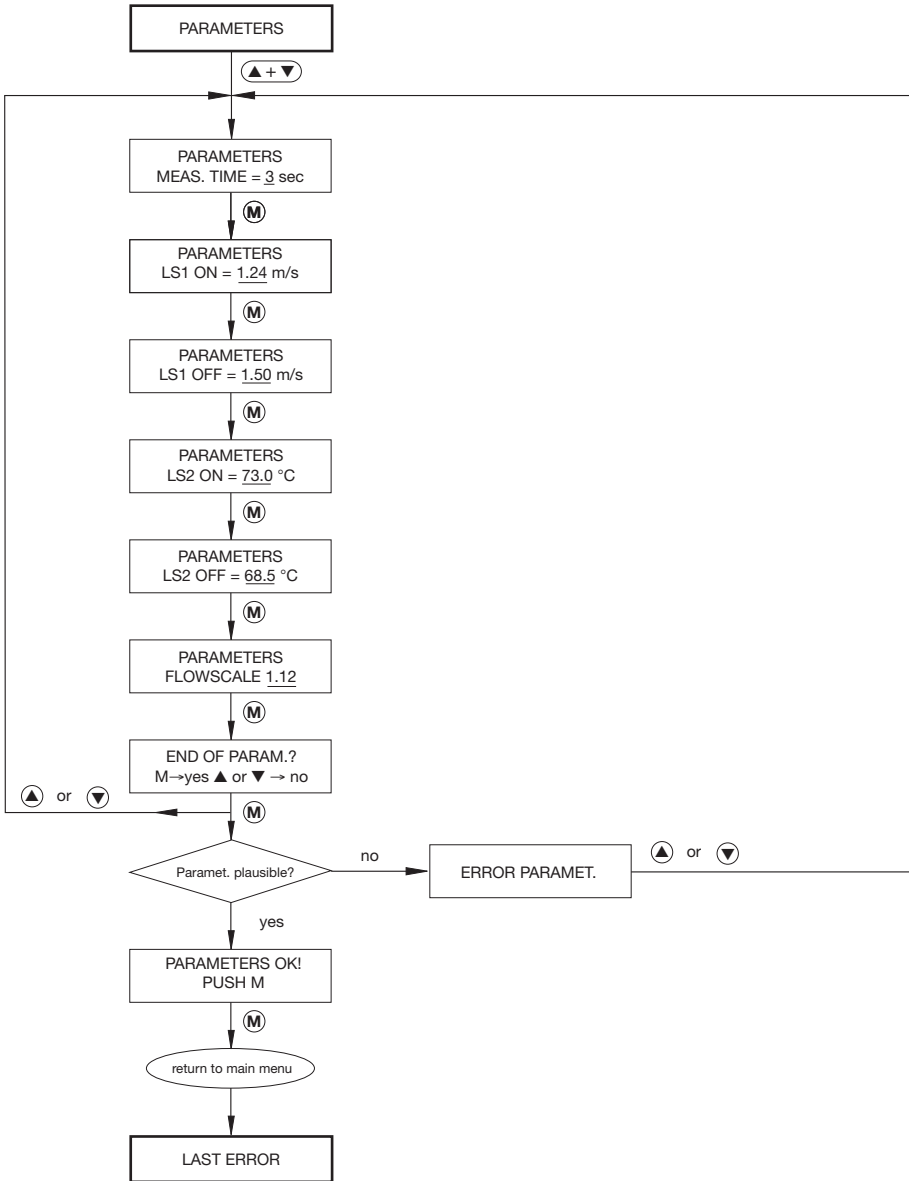

7 Low flow suppression

The low flow suppression menu option serves to suppress small flow quantities and to detect leakages. Menu settings can be changed during the measuring operation, requiring no additional heating period.

7.1 Low flow suppression

The low flow suppression option ranging from 1 to 10 % of the measuring range final value can be used to eliminate false measurements as may arise upon (small) reverse flow quantities, for example. If flow velocity is less than the value set, the flow velocity and the applicable flow is set at zero. This also applies to all subsequent quantities such as analogue output, bar graph and limit switches which are defined in the other menus.

7.2 Zero adjustment

Although because of its very special characteristic curve in the lower flow range the calorimetric procedure implies a higher resolution than other measuring procedures, it is not possible to exactly measure zero flow, the reason for this being that in the lower flow range (<1 % of measuring range final value) current flow is superimposed by convection flow around the heated monitoring head sensor. Convection flow is very difficult to theoretically detect for all measuring systems (monitoring head and FC01-CA); it is determined by installation and current pressure and temperature, etc. Selecting 0 % will therefore always result in zero adjustment.

To ensure correct zero adjustment, the pipeline should be operated under the desired pressure and temperature conditions, and a waiting period of approx. 2 ... 5 minutes should be observed after the pipe system has been closed (zero volume flow) to ensure correct setting. If the FC01-CA indicates flow after pipeline has been opened, there is definitely flow available.

After this adjustment even smallest volume flow quantities can be reliably indicated.

Caution!



No plausibility test to ensure there is no volume flow is conducted for zero adjustment. The volume flow available at that time is set at zero. This should be considered above all for untight valves in which case the zero volume flow determined this way may even be greater than 1 %. Accuracy in the lower measuring range will decrease then. To be on the safe side, the lower limit should therefore be set at 1 % if no reliable zero adjustment can be made.

8 Errors

8.1 Test and diagnosis

The FC01-CA is provided with extensive test and diagnosis functions.

All faults found will be shown in the display with the corresponding error number (e.g. ERROR 10). If the FC01-CA is fitted with a T4 option (4 transistor outputs), the output ERROR will additionally be activated.

The functions may be classified in three priority groups.

8.1.1 Priority group I

Priority group I comprises the switch-on test routines (FC01-CA self-test) which are carried out when the system is switched on.

Their implementation is indicated.

Errors No. 1 to 5 do not allow system operation.

The test routines may be repeated by pressing any of the switches.

If even after several trials the switch-on test cannot be conducted without error indication, the system should be returned to the supplier for rectification, indicating the error number.

Priority I errors cannot be rectified by the user!

8.1.2 Priority group II

These test functions are continuously carried out during operation. The occurrence of errors No. 10 and 21 will cause measurements to stop, indicating the error and monitoring the source of the error. Upon rectification of the error, the system will automatically return to measuring operation.

8.1.3 Priority group III

These test routines are also continuously carried out during operation.

Other than the above priority groups, errors No. 20, 30, 60, 40 and 41 will not cause measurements to stop; the error output will indicate and the number of the error will be shown on the display.

8.2 Potential errors

Independent of the priority group, all errors found are indicated with their relevant number.

In order to facilitate operation, the last error is stored in a non-volatile memory. The stored error may be retrieved and deleted in the main menu.

If a combination of errors occurs simultaneously, they are indicated or stored in the error memory observing the following sequence.

Priority group I

Error	Cause	Rectification
No. 1	No system parameter available	Return to supplier.
No. 2	Incorrect test sum of parameter memory	Return to supplier.
No. 3	Incorrect test sum of program memory	Return to supplier.
No. 4	Incorrect test sum of data memory	Return to supplier.
No. 5	Internal controller error	Return to supplier.

Priority group II

Error	Cause	Rectification
No. 10	Sensor not connected; or cable between FC01-CA and sensor defective; or defective sensor	Check cable or replace sensor.
	Sensor selected (configuration) differs from sensor connected	Correct sensor selection in configuration menu
No. 21	Medium temperature too high	

Priority group III

Error	Cause	Rectification
No. 20	Medium temperature too low	
No. 30	Over limits of flow rate	
No. 60	Assignment of quantity per pulse too low *	
No. 40	Controller error (oscillator-watchdog) Admissible EMC levels may have been exceeded	
No. 41	Controller error (watchdog timer) Admissible EMC levels may have been exceeded	

* Error No. 60 can only occur with version FC01-CA-U1T4.

9 Technical data

9.1 Ambient conditions

	rail-mounted	surface mounted	front panel mounted
Storage temperature:	-20 ... +70 °C	-20 ... +70 °C	-20 ... +70 °C
Ambient temperature: *	+10 ... +50 °C **	+10 ... +50 °C	+10 ... +50 °C
Degree of protection:	IP20	IP65	IP65

* Only if the modules are spaced by at least 10 mm.

** The max. ambient temperature of +40 °C applies to all systems fitted with current output C1.

9.2 Electrical characteristics

9.2.1 Power supply

DC supply

Steckerbelegung:	Signal name	Pin XV
	shield	1
	+U _V	2
	-U _V	3

9.2.1.1 DC voltage supply

Supply voltage:	U _{VN} = DC 24 V *
Input voltage range: (ripple incl.)	U _V = DC 19 V to DC 32 V
Admissible ripple:	max. 20 % U _V
Rated current consumption:	I _{Vnk} = 170 mA with zero flow I _{Vnk} = 200 mA with max. flow (end of measuring range)

Power consumption may be up to 300 mA ± 10 % when analogue output C1 is fitted.

* DC 12 V possible if the FC01-CA is used without option C1 (analogue output 0/4 ... 20 mA).

Inrush current:	I _p = typ. 3 A (20 μs)
Switch-off current:	I _{kipp} = typ. 0.75 A
Rated power consumption:	P _n = 4.1 W with zero flow, voltage outputs P _n = 4.8 W with max. flow (end of measuring range), voltage outputs
Insulation voltage:	supply input - central electronic unit ≥ DC 500 V

9.3 Analogue outputs

The analogue outputs are physically isolated from each other as well as from the electronic control unit FC01-CA.

Pin selection for analogue outputs V1, V2 and C1

Signal name	Pin XAO
NC	1
analogue output 1 - flow rate	2
reference ground 1	3
shield 1 *	4
shield 2 *	5
analogue output 2 - temperature	6
reference ground 2	7
NC	8
NC - not used	

Analogue output 1 - ANA OUT FLOW (flow output)

Analogue output 2 - ANA OUT TEMP. (temperature output)

*** Shield ungrounded - apply on one side only.**

The output is reverse polarity protected.

Insulation voltage:	analogue output - analogue output DC 500 V
	analogue output - central electronic unit DC 500 V

9.3.1 Voltage output V1 - 5 V FS

Signal voltage range:	$U_S = 0 \text{ V (1 V) to } 5 \text{ V } \pm 2 \% \text{ FS}$
Max. signal ripple:	$dU_S = 5 \% \text{ FS}$
Min. admissible load resistance:	$R_l = 1 \text{ k}$
Max. admissible load capacity:	$C_l = 1 \text{ nF}$
Max. admissible load inductance:	$L_l = 100 \text{ nH}$
Short circuit proof:	yes (XAO - between all terminals)

9.3.2 Voltage output V2 - 10 V FS

Signal voltage range:	$U_S = 0 \text{ V (2 V) to } 10 \text{ V } \pm 2 \% \text{ FS}$
Max. signal ripple:	$dU_S = 5 \% \text{ FS}$
Min. admissible load resistance:	$R_l = 1 \text{ k}$
Max. admissible load capacity:	$C_l = 1 \text{ nF}$
Max. admissible load inductance:	$L_l = 100 \text{ nH}$
Short circuit proof:	yes (XAO - between all terminals)

9.3.3 Current output C1 - 20 mA FS

Signal current range:	$I_S = 0 \text{ mA (4 mA) to } 20 \text{ mA } \pm 2 \% \text{ FS}$
Max. signal ripple:	$dI_S = 5 \% \text{ FS}$
Min. admissible load resistance:	$R_l = 0$
Max. admissible load resistance:	$R_l = 250$

9.4 Signal outputs

The signal outputs are physically isolated from each other as well as from the electronic control unit FC01-CA.

9.4.1 Relay outputs R2 (DC or AC)

Pin selection:	Signal name	Pin XAH
	Limit Switch 1 / shield	1
	Limit Switch 1 / N/O	2
	Limit Switch 1 / common	3
	Limit Switch 1 / N/C	4
	Limit Switch 2 / shield	5
	Limit Switch 2 / N/O	6
	Limit Switch 2 / common	7
	Limit Switch 2 / N/C	8

Resistive load

Max. admissible switching capacity:	50 W
Max. admissible switching current:	1 A
Max. admissible continuous current:	1 A
Max. admissible switching voltage:	50 V
Contact life at 1 A:	3 x 10 ⁵ cycles

Inductive load - with safety circuit - AC voltage

Max. admissible switching capacity:	125 VA
Max. admissible switching current:	1.25 A
Max. admissible continuous current:	1.25 A
Max. admissible switching voltage:	100 V
Contact life $\cos \varphi = 0.5$:	2.4 x 10 ⁵ cycles
Insulation voltage:	signal contact - central electronic unit DC 500 V
	signal contact - signal contact DC 500 V

9.4.2 Transistor outputs (DC)

Pin selection:	Signal name	Pin XAH	Polarity
	/ ERROR emitter	1	-
	/ ERROR collector	2	+
	/ BUSY / PULSE emitter	3	-
	/ BUSY / PULSE collector	4	+
	Limit Switch 2 emitter	5	-
	Limit Switch 2 collector	6	+
	Limit Switch 1 emitter	7	-
	Limit Switch 1 collector	8	+

Voltage level

Low level - active:	$U_{ce} < 0.8 \text{ V}$ at $I_C < 10 \text{ mA}$ $U_{ce} < 1 \text{ V}$ at $I_C < 100 \text{ mA}$
High level - passive:	$U_{ce} < 48 \text{ V}$ $U_{ce \text{ max}} = 60 \text{ V}$ max. leakage current $\leq 25 \mu\text{A}$
Reverse polarity protection:	yes
Short circuit protection:	yes

Resistive load

Max. admissible switching capacity:	1.5 W
Max. admissible switching current:	150 mA
Max. admissible switching voltage:	36 V

Inductive load - L < 100 mH

(DC voltage - without external safety circuit)

Max. admissible switching capacity:	1.5 VA
Max. admissible switching current:	40 mA
Max. admissible switching voltage:	36 V

Capacitive load - C < 20 μF

Max. admissible switching capacity:	1.5 VA
Max. admissible switching current:	1.5 A
Max. admissible switching voltage:	36 V
Insulation voltage:	signal contact - central electronic unit DC 500 V signal contact - signal contact DC 500 V

9.5 Metrological data

9.5.1 Flow rate measurement

Measuring is possible up to the flow rates indicated in the display range. However, the indicated accuracy is no longer guaranteed. **The repeatability value remains valid.**

Medium: air

9.5.1.1 Monitoring head CSP with sensor adapter type TP-..

Flow measurement ranges:

Sensor adapter type	Measuring range in Nm ³ /h	Display range in Nm ³ /h
TP01	0 ... 50	70
TP02	0 ... 77	109
TP03	0 ... 120	170
TP04	0 ... 197	280
TP05	0 ... 308	439
TP06	0 ... 480	685

Response delay: 3 s
 Accuracy ¹⁾: ± 3% MW ** / ±0.1 % MBE *
 Repeatability: ± 1% MW / ±0.5 % MBE
 (5 % MBE to 100 % MBE)
 Temperature drift: ± 0.05 %/K/MBE

* MBE - of final value

** MW - measured value

¹⁾ Please enquire for higher accuracy.

9.5.1.2 Monitoring head CSF-..

Flow measurement ranges:

The flow measurement range is determined by the inner pipe diameter (see table). It can be calculated with the following equation:

$$Q = V_N \times a$$

Q [Nm³/h] - flow quantity

V_N [m/h] - average standard velocity

a [m²] - inner pipe cross-section

Inner pipe diameter D in mm	Measuring range in Nm ³ /h	Display range in Nm ³ /h
20	76	113
30	173	254
40	307	452
50	480	706
60	692	1017
70	942	1385
80	1230	1809
90	1557	2290
100	1922	2827
150	4325	6361
200	7690	11309
250	12016	17671
300	17303	25446
400	30762	45238
500	48066	70685
600	69215	101787
700	94210	138544
800	123049	180955
900	155734	229021
1000	192265	282743

Setting range for internal pipe diameter:	10.0 mm ... 999.9 mm
Velocity range:	0 ... 68 Nm/s (100 Nm/s)
Accuracy ¹⁾ :	± 5 % MW ** / ±0.5 % MBE *
Repeatability: (5% MBE to 100 % MBE)	± 1 % MW / ±0.5 % MBE
Temperature drift:	± 0.05 %/K/MBE

9.5.2 Temperature measurement:

Measuring range:	- 40 ... +130 °C
Accuracy:	±1 % MB ***

9.5.3 Electronic control unit FC01-CA

Temperature drift:	0.1 %/K/MBE * (CSP-...)
	0.05 %/K/MBE * (CSF-...)

Heating up period until full accuracy is reached:	15 min.
---	---------

* MBE - of final value

** MW - measured value

*** MB - measuring range

9.6 Sensor interface

9.6.1 Electrical data of the terminal for calorimetric monitoring heads

Terminal	Mnemonics	Data
XSK1	R(HEIZ)-LO	Function: terminal for negative pole of heater element Drain output of heating current control Max. sink current: $I_{\text{sink}} = 88 \text{ mA}$ Dielectric strength: $-0.5 \text{ V} \dots +20 \text{ V DC}$
XSK2	R(HEIZ)-HI	Function: terminal for positive pole of heater element Hi-potential of heater source Output voltage range (load dependent) $U_a = 21 \text{ V} \dots 24 \text{ V DC}$ Max. current output: $I_{\text{max}} = 100 \text{ mA}$ Not short-circuit proof
XSK3	R(Tref)-HI	Function: terminal for positive RTD * pole for medium temperature measurement Input resistance: $> 1 \text{ G}$ Dielectric strength: $-17 \text{ V} \dots +30 \text{ V DC}$
XSK4	R(Tref)-LO	Function: terminal for negative RTD * pole for medium temperature measurement Input resistance: $> 1 \text{ G}$ Dielectric strength: $-17 \text{ V} \dots +30 \text{ V DC}$
XSK5	AGND	Function: analogue ground Reference potential of excitation current source for RTD * operation
XSK6	IS	Function: output of excitation current source for RTD * operation Excitation current: $1 \text{ mA} \pm 1\%$ Admissible load range: $R_{\text{load}} = 0 \dots 2 \text{ k}$ Dielectric strength: $\pm 15 \text{ V DC}$
XSK7 XSK8	SGND	Function: shield ground Terminals for sensor cable shielding
XSK9	R(Tdiff)-LO	Function: terminal for negative pole of the heated RTD * Input resistance: $> 1 \text{ G}$ Dielectric strength: $-17 \text{ V} \dots +30 \text{ V DC}$
XSK10	R(Tdiff)-HI	Function: terminal for positive pole of the heated RTD * Input resistance: $> 1 \text{ G}$ Dielectric strength: $-17 \text{ V} \dots +30 \text{ V DC}$

* RTD = **R**esistive **T**emperature **D**evice

10 Accessories

No.	Accessory	Ordering configuration
1	Surface mounted housing	FC01-CA-FH
2	Front mounted housing	FC01-CA-ST
3	Connecting cable for calorimetric monitoring head cable type LifYCY 4 x 2 x 0.2 mm ² - type 15 / -10 °C ... +80 °C highly flexible/paired - type 18 / -60 °C ... +200 °C non-halogenous/highly flexible/paired	Do+Ka
4	Calorimetric monitoring heads	CSP / CSF
5	Sensor adapter (screw-in or welding type)	TP
6	Ball valve	BV
7	Locking set 01 (for monitoring head CSF-..)	0Z122Z000204

Index

A	Seite
ANA OUT FLOW	41, 43, 46
ANA OUT TEMP	41, 43, 46
Analogue outputs	5, 21, 56
B	
Ball valve	10, 44
BARGRAPH	39, 46
C	
CONFIGURATION	34, 43
D	
DISPLAY SELECT	38, 43, 46
E	
ERROR	52
F	
FLOW UNIT	37, 43, 45
FLOWSCALE	48, 50
FREQUENCY OUTPUT	4, 26, 40, 46
Front panel mounted version FC01-CA-ST-U1...	19, 56
G	
GAS SELECT	36, 43, 45
I	
Insertion head CSP-..	8, 44, 60
K	
Keypads	27
L	
LAST ERROR	32, 33
Leakage measurement	3
LIMIT SWITCHES	36, 43, 45
Low flow suppression	51

LS1 OFF	47, 50
LS1 ON	47, 50
LS2 OFF	48, 50
LS2 ON	48, 50

M

Main menu	33
MEAS. TIME	47, 50

O

Operating volume	3
------------------------	---

P

PARAMETERS, parameter selection	33, 47, 50
PEAK VALUE MAX	32, 33
PEAK VALUE MIN	32, 33
PIPE SIZE	35, 44
Power supply	6, 20, 55
PRESS. RANGE	35, 43, 44
Push-in monitoring head CSF-11AM1	11, 35, 44, 61

R

Rail-mounted version FC01-CA-U1... ..	17, 55
Relay outputs	4, 5, 21, 22, 58

S

SENSOR CODE	34, 44
SENSOR SELECT	34, 43, 44
Sensor adapter TP-.. ..	9, 60
Signal outputs	5, 22, 58
STANDARD FLOW	35
Surface mounted housing FC01-CA-FH-U1... ..	18, 56

T

TEMP. UNIT	37, 43, 46
TOTALISATOR	39
Transistor outputs	4, 5, 21, 24, 59

X

XAH - Signal outputs - Relay outputs 21
XAH - Signal outputs - Transistor outputs 21
XAO - Analogue outputs 21
XAS - Sekundärstromversorgung 22
XSK - Connection of calorimetric monitoring heads type CS_x 22
XTF - Keyboard release 20
XV - Power supply 20

Z

ZERO SUPP. 32, 33

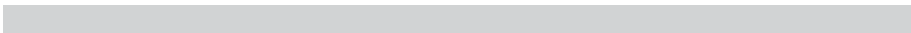

Appendix 1 - Performance of the digital and analogue outputs during the operating and error modes

Duty/ Error status	LIMIT SWITCH 1	LIMIT SWITCH 2	NO ERROR	NOT BUSY and FREQUENCY OUTPUT	ANA OUT FLOW	ANA OUT TEMP.
Start-up (Reset)	ON	ON	ON	ON	MAX	MAX
Start-up test active	OFF	OFF	OFF	OFF	MIN	MIN
Error No. 1	OFF	OFF	OFF	OFF	MIN	MIN
Error No. 2	OFF	OFF	OFF	OFF	MIN	MIN
Error No. 3	OFF	OFF	OFF	OFF	MIN	MIN
Error No. 4	OFF	OFF	OFF	OFF	MIN	MIN
Error No. 5	OFF	OFF	OFF	OFF	MIN	MIN
Heating period active	OFF	OFF	ON	OFF	MIN	MIN
Normal duty	X	X	ON	ON	X	X
Configuration active	OFF	OFF	ON	OFF	MIN	MIN
Parameter selection active	OFF	OFF	ON	OFF	MIN	MIN
Error No. 10	OFF	OFF	OFF	OFF	MIN	MIN
Error No. 20	X	X	OFF	ON	X	X
Error No. 21	OFF	OFF	OFF	OFF	MIN	MIN
Error No. 30	X	X	OFF	ON	X	X
Error No. 60 *	X	X	OFF	FA	X	X
Error No. 40	X	X	Y	ON	X	X
Error No. 41	X	X	Y	ON	X	X

X = standard performance

Y = OFF pulse

FA = frequency output 10 Hz

* When frequency output has been selected.

Note: The occurrence of error No. 40/41 will always cause an internal reset.

Status of the outputs prior to the error status described → see start-up (reset)

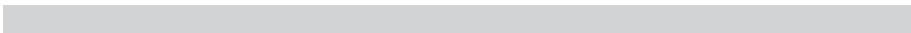

Appendix 2 - Menu structure of the FC01-CA (operator dialog)

